

Model 990 Computer Model DS10 Cartridge Disk System

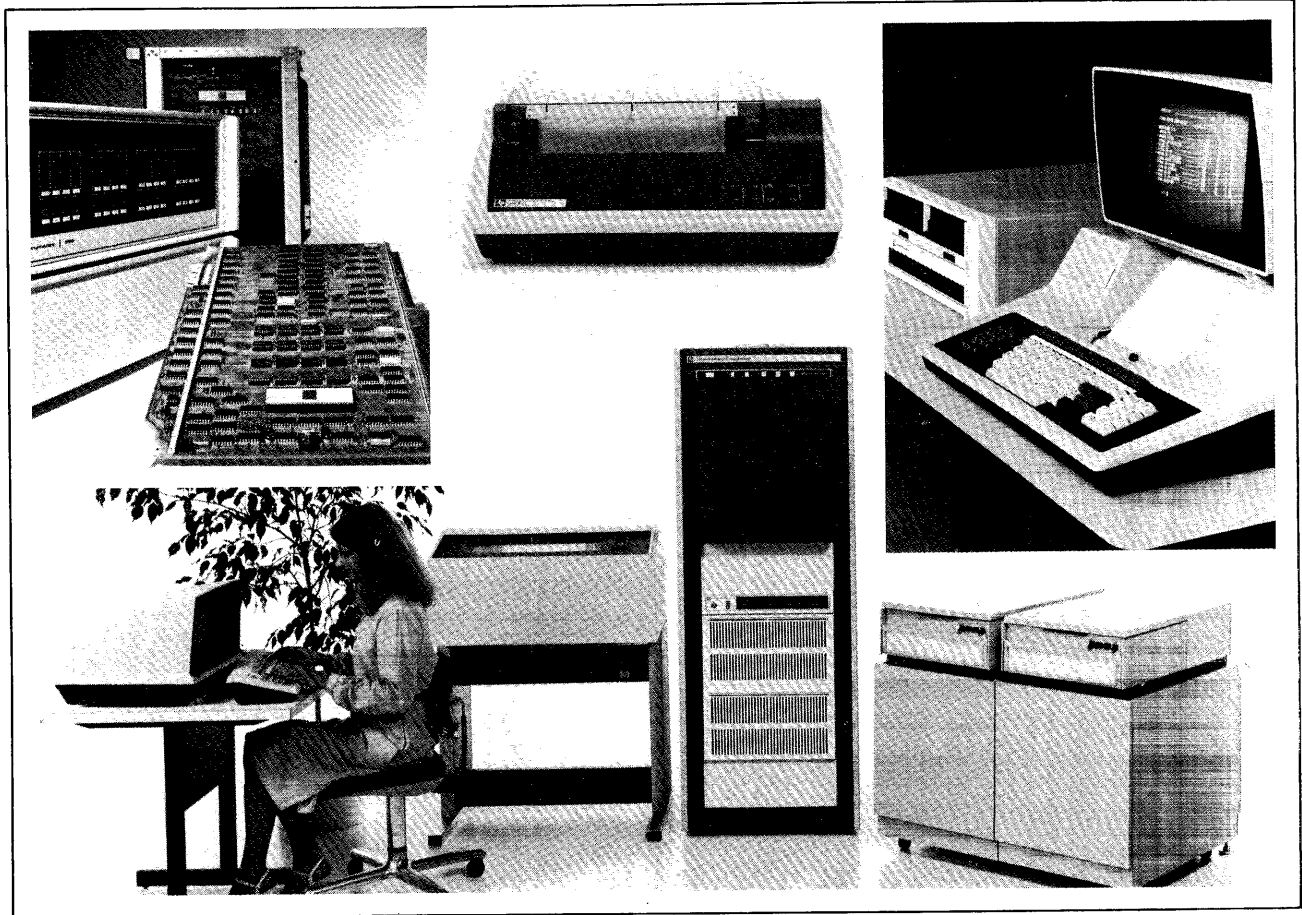

Installation and Operation

Part No. 946261-9701 *B
15 December 1980



TEXAS INSTRUMENTS

© Texas Instruments Incorporated 1977, 1978, 1979, 1980

All Rights Reserved, Printed in U.S.A.

The information and/or drawings set forth in this document and all rights in and to inventions disclosed herein and patents which might be granted thereon disclosing or employing the materials, methods, techniques or apparatus described herein, are the exclusive property of Texas Instruments Incorporated.

MANUAL REVISION HISTORY

Model 990 Computer Model DS10 Cartridge Disk System
Installation and Operation (946261-9701 *B)

Original Issue	1 December 1977
Change 1	15 January 1978 (ECN 419819)
Change 2	15 August 1978 (ECN 437233)
Change 3	15 March 1979 (ECN 449602)
Change 4	15 August 1980 (MCR 000297)
Revision.....	15 December 1980 (MCR 000440)

The total number of pages in this publication is 126.



PREFACE

This manual provides detailed instructions for installing a Texas Instruments Model DS10 Cartridge Disk System in conjunction with a properly installed Model 990 Computer. In addition, it contains information required to program the computer to use the disk system and a description of the disk system with specific attention to the controls and indicators. The information is divided into the following sections:

Section

- 1 **General Description** – This section briefly describes the features and major components of the disk system to acquaint the reader with the system.
- 2 **Installation** – This section contains step-by-step procedures for unpacking and installing a Model DS10 Cartridge Disk System. Information is also provided to ensure that the site for the installation is properly prepared prior to installation of the disk system. The procedures given in this section presuppose that the reader is not familiar with digital electronics.
- 3 **Programming** – This section presents interfacing information for use by a programmer in designing a service routine to control the disk system's activity.
- 4 **Operation** – This section describes the controls and indicators of the disk system for disk system operators, and describes the use of those controls and indicators in the operation of the disk system.

Title	Part Number
<i>Model 990/5 Computer System Hardware User's Manual</i>	946294-9701
<i>Model 990/10 Computer System Hardware Reference Manual</i>	945417-9701
<i>Model 990/12 Computer Hardware User's Manual</i>	2264446-9701
<i>Model 990 Computer Model DS10 Cartridge Disk System Depot Maintenance Manual</i>	946262-9701
<i>Model 990 Computer Programming Card</i>	943440-9701
<i>Model 990 Computer TMS 9900 Microprocessor Assembly Language Programmer's Guide</i>	943441-9701



TABLE OF CONTENTS

Paragraph	Title	Page
SECTION 1. GENERAL DESCRIPTION		
1.1	General	1-1
1.2	System Configuration	1-1
1.2.1	TILINE Bus	1-2
1.2.2	Disk Controller	1-5
1.2.3	Disk Drives	1-5
1.3	System Operation	1-6
1.4	System Specifications	1-10
SECTION 2. INSTALLATION		
2.1	General	2-1
2.2	Site Requirements	2-2
2.2.1	Mounting Space Requirements for Rack Mount Disk Drive	2-2
2.2.2	Mounting Space Requirements for Cabinet Mount Disk Drive	2-2
2.2.3	Ac Power Requirements	2-5
2.2.4	Model 990 Computer	2-5
2.2.5	Supportive Environment	2-6
2.2.6	Cabling Restrictions	2-6
2.3	Unpacking Instructions	2-6
2.3.1	Unpacking Rack Mount Disk Drive	2-6
2.3.2	Unpacking Disk Controller	2-12
2.3.3	Unpacking Cabinet Mount Disk Drive	2-17
2.3.4	Unpacking Accessories	2-21
2.3.5	Unpacking, Handling, and Storing Disk Cartridges	2-21
2.3.5.1	Unpacking Disk Cartridges	2-22
2.3.5.2	Handling Disk Cartridges	2-22
2.3.5.3	Storing Disk Cartridges	2-23
2.3.6	Voltage Conversion Procedures	2-24
2.4	Installation	2-24
2.4.1	Installation of Rack Mount Disk Drive	2-24
2.4.2	Installation of Cabinet Mount Disk Drive	2-28
2.4.3	Computer Chassis Preparation for Disk Controller	2-29
2.4.3.1	Reconfiguring Access Granted Circuit for New Chassis Slot (6- and 13-Slot Chassis)	2-29
2.4.3.2	Reconfiguring Access Granted Circuit for New Chassis Slot (17-Slot Chassis)	2-34
2.4.3.3	Interrupt Connections for 6- and 13-Slot Chassis	2-37
2.4.3.4	Interrupt Connections for 17-Slot Chassis	2-39
2.4.4	Preparation of Disk Controller	2-42
2.4.4.1	Selecting Disk TILINE Address	2-42
2.4.5	Installation of Disk Controller	2-42
2.4.6	Installing Disk System Interconnection Cables	2-42
2.4.7	Connection of Disk Drive to Ac Power Source	2-49
2.4.8	Disk Cartridge Installation and Removal	2-51
2.4.8.1	Purging the Disk Drive Air Filtering System	2-51
2.4.8.2	Disk Cartridge Installation	2-52



TABLE OF CONTENTS (Continued)

Paragraph	Title	Page
2.4.8.3	Disk Cartridge Removal	2-56
2.4.8.4	Removal of Disk Cartridge Following Power Failure or for Emergency	2-58
2.5	System Operational Checkout	2-59

SECTION 3. PROGRAMMING

3.1	General	3-1
3.2	Programming the Disk Controller	3-1
3.3	Command Control	3-1
3.4	Command Completion	3-1
3.4.1	Command Completion without Interrupts	3-3
3.4.2	Command Completion with Interrupts	3-3
3.4.2.1	Command Completion Interrupts	3-3
3.4.2.2	Seek and Restore Completion Interrupts	3-3
3.5	Control Words Content and Formats	3-3
3.5.1	Disk Status, Control Word 0	3-3
3.5.2	Command Control, Control Word 1	3-4
3.5.3	Format and Sector, Control Word 2	3-5
3.5.4	Cylinders, Control Word 3	3-6
3.5.5	Word Count, Control Word 4	3-6
3.5.6	LSB Memory Address, Control Word 5	3-7
3.5.7	Unit Select and MSB Memory Address, Control Word 6	3-7
3.5.8	Interrupt and Controller Status, Control Word 7	3-8
3.5.9	Disk Commands	3-10
3.5.9.1	Store Registers Command	3-10
3.5.9.2	Write Format Command	3-10
3.5.9.3	Read Data Command	3-12
3.5.9.4	Write Data Command	3-13
3.5.9.5	Read Unformatted Command	3-14
3.5.9.6	Unformatted Write Command	3-15
3.5.9.7	Seek Command	3-15
3.5.9.8	Restore Command	3-15
3.6	Formats and Definitions	3-16
3.6.1	Definition of Terms	3-16
3.6.2	Sector Format	3-16
3.6.2.1	Gap 1	3-17
3.6.2.2	Synchronization (Sync) Character	3-17
3.6.2.3	Identification (ID) Words	3-17
3.6.2.4	Error Detection Code (EDC) Number 1	3-18
3.6.2.5	Gap 2	3-18
3.6.2.6	Data	3-18
3.6.2.7	Error Detection Code (EDC) Number 2	3-18
3.6.2.8	Gap 3	3-18

SECTION 4. OPERATION

4.1	General	4-1
4.2	Controls and Indicators	4-1
4.2.1	Ac Circuit Breaker	4-1



TABLE OF CONTENTS (Continued)

Paragraph	Title	Page
4.2.2	Dc Circuit Breaker	4-1
4.2.3	START/STOP Switch/Indicator	4-1
4.2.4	READY Indicator	4-2
4.2.5	ACTIVE Indicator	4-2
4.2.6	FAULT/RESET Indicator/Switch	4-2
4.2.7	WRITE/PROTECT CART Indicator/Switch	4-3
4.2.8	WRITE/PROTECT FIXED Indicator/Switch	4-3
4.2.9	BRUSH Indicator	4-3
4.3	Operating Instructions	4-3
4.3.1	Operating Precautions	4-3
4.3.2	Power Application for Online Operation	4-4
4.3.3	Disk Cartridge Installation and Removal	4-4
4.3.3.1	Disk Cartridge Installation	4-4
4.3.3.2	Disk Cartridge Removal	4-5
4.3.3.3	Removal of Disk Cartridge Following Power Failure or for Emergency	4-6
4.3.4	Write Protect	4-6
4.3.5	Stop and Power Removal	4-6
4.3.6	Changing Disk Assignments	4-7
4.3.7	Fault Operating Procedures	4-7
4.3.8	Operator Preventive Maintenance	4-7
4.4	Maintenance Aids	4-7
4.5	Preventive Maintenance	4-11
4.5.1	Preventive Maintenance for the Rack Mount Disk Drive	4-11
4.5.2	Preventive Maintenance for the Cabinet Mount Disk Drive	4-11
4.5.3	Preventive Maintenance for the Cartridge Disk	4-12
4.5.3.1	General	4-12
4.5.3.2	Maintenance Procedures	4-13

LIST OF ILLUSTRATIONS

Table	Title	Page
1-1	Model DS10 Cartridge Disk System	1-0
1-2	Model DS10 Cartridge Disk Unit Subsystem Simplified Diagram	1-2
1-3	TILINE Master-to-Slave Write Cycle Timing	1-3
1-4	TILINE Master-to-Slave Read Cycle Timing	1-4
1-5	Interconnection of Disk Controller and Two Disk Drives	1-6
1-6	Model DS10 Cartridge Disk Controller (PWB)	1-7
1-7	Model DS10 Cartridge Disk Controller (Fine Line PWB)	1-8
1-8	Model DS10 Cartridge Disk Drive (Cabinet Mount)	1-9
1-9	Rack Mount Disk Drive Physical Dimensions	1-11
1-10	Cabinet Mount Disk Drive Physical Dimensions	1-12
2-1	Model DS10 Cartridge Disk System Components	2-3
2-2	Recommended Rack Dimensions for Model DS10 Cartridge Disk Drive	2-4
2-3	Physical Dimensions of Cabinet Mount Model DS10 Cartridge Disk Drive	2-5
2-4	Rack Mount Disk Drive Shipping Configuration	2-7
2-5	Cabinet Mount Disk Drive Shipping Configuration	2-8
2-6	Placement of Disk Drive for Shipping Bolt Removal	2-9



LIST OF ILLUSTRATIONS (Continued)

Figure	Title	Page
2-7	Location of Electronics Cover Screws	2-10
2-8	Carriage Lock Pin Location	2-11
2-9	Card Cage Cover and Clamp Location	2-12
2-10	Disk Drive PWB Locations	2-13
2-11	Control PWB Switch Settings	2-14
2-12	Sector PWB Switch Settings	2-15
2-13	Servo PWB Switch Settings	2-16
2-14	Data Recovery PWB Switch Settings	2-17
2-15	R/W/E PWB Resistor Module Orientation	2-18
2-16	Disk Controller Shipping Configuration	2-19
2-17	Disk Controller Standard Jumpers	2-20
2-18	Disk Cartridge	2-23
2-19	Voltage Jumper Plug and Connector	2-25
2-20	Rack Slide Assembly Mounting	2-27
2-21	Rack Mount Slide Configuration (Right Side Only)	2-28
2-22	TILINE Access Granted Jumper Locations for 6-Slot Chassis (Current Production)	2-31
2-23	TILINE Access Granted Jumper Locations for 13-Slot Chassis (Current Production)	2-32
2-24	TILINE Access Granted Jumpers (P2-5 to P2-6) on the Model 990 Backpanel	2-33
2-25	Interrupt Plug and TLAG Jumper Switches in the 17-Slot Chassis	2-35
2-26	17-Slot Chassis TLAG Jumper Switch Settings	2-36
2-27	Location of Interrupt Jumpers (6- and 13-Slot Chassis)	2-37
2-28	6-Slot Chassis Interrupt Jumper Plugs	2-39
2-29	13-Slot Chassis Interrupt Jumper Plugs	2-40
2-30	17-Slot Chassis Interrupt Jumper Connector	2-41
2-31	Model DS10 Cartridge Disk Controller (PWB)	2-43
2-32	TILINE Slave Address Switches	2-44
2-33	Interconnection Cable Connector Mating	2-45
2-34	Interconnection Cable Dressing in Computer Chassis	2-46
2-35	Cable Adapter	2-47
2-36	Cable Arrangement on Cable Carriers	2-48
2-37	XRM (n) Resistor Packs to be Removed from Primary Rack Mount Disk Drive I/O Board	2-50
2-38	XRM (n) Resistor Packs to be Removed from Primary Cabinet Mount Disk Drive I/O Board	2-50
2-39	Switches and Settings for Rack Mount Primary Disk Drive	2-53
2-40	Switches and Settings for Cabinet Mount Primary Disk Drive	2-54
2-41	Disk Drive Circuit Breakers	2-55
2-42	Brush Indicator	2-56
2-43	Disk Cartridge Installation	2-57
2-44	Cartridge Locks	2-58
3-1	Model DS10 Disk System Control Word Formats	3-2
3-2	Control Word 0	3-3
3-3	Control Word 1	3-4
3-4	Control Word 2	3-6
3-5	Control Word 3	3-6
3-6	Control Word 4	3-6
3-7	Control Word 5	3-7
3-8	Control Word 6	3-7

**LIST OF ILLUSTRATIONS (Continued)**

Figure	Title	Page
3-9	Control Word 7	3-8
3-10	Command Format	3-10
3-11	Store Registers Data Format	3-11
3-12	Header Data Format	3-12
3-13	Format of a Sector Record Bit Stream	3-17
4-1	Disk Drive Controls and Indicators	4-2
4-2	Disk Designation Jumper	4-8
4-3	Disk Controller LEDs (PWB Version)	4-9
4-4	Disk Controller LEDs (Fine Line PWB Version)	4-10
4-5	Disk Contaminants	4-13

LIST OF TABLES

Table	Title	Page
1-1	Disk Drive Specifications	1-10
1-2	General Characteristics of Model DS10 Cartridge Disk System	1-11
1-3	Ac Power Requirements for Disk Drive (Both 50- and 60-Hertz Drives)	1-13
2-1	Model DS10 Cartridge Disk System Components	2-2
2-2	Site Environmental Requirements for Model DS10 Cartridge Disk System	2-6
2-3	Disk Drive Input Voltage Jumper Connections	2-26
2-4	TILINE Slave Address Switch Settings and Addresses	2-44
3-1	Disk Command Bits	3-5
3-2	Example of List Words in a Store Registers Command	3-11
3-3	Write Format Command	3-11
3-4	Example of Read Data	3-12
3-5	Read Unformatted Command Example	3-14
3-6	Example of a Seek Command	3-15



946261-9701

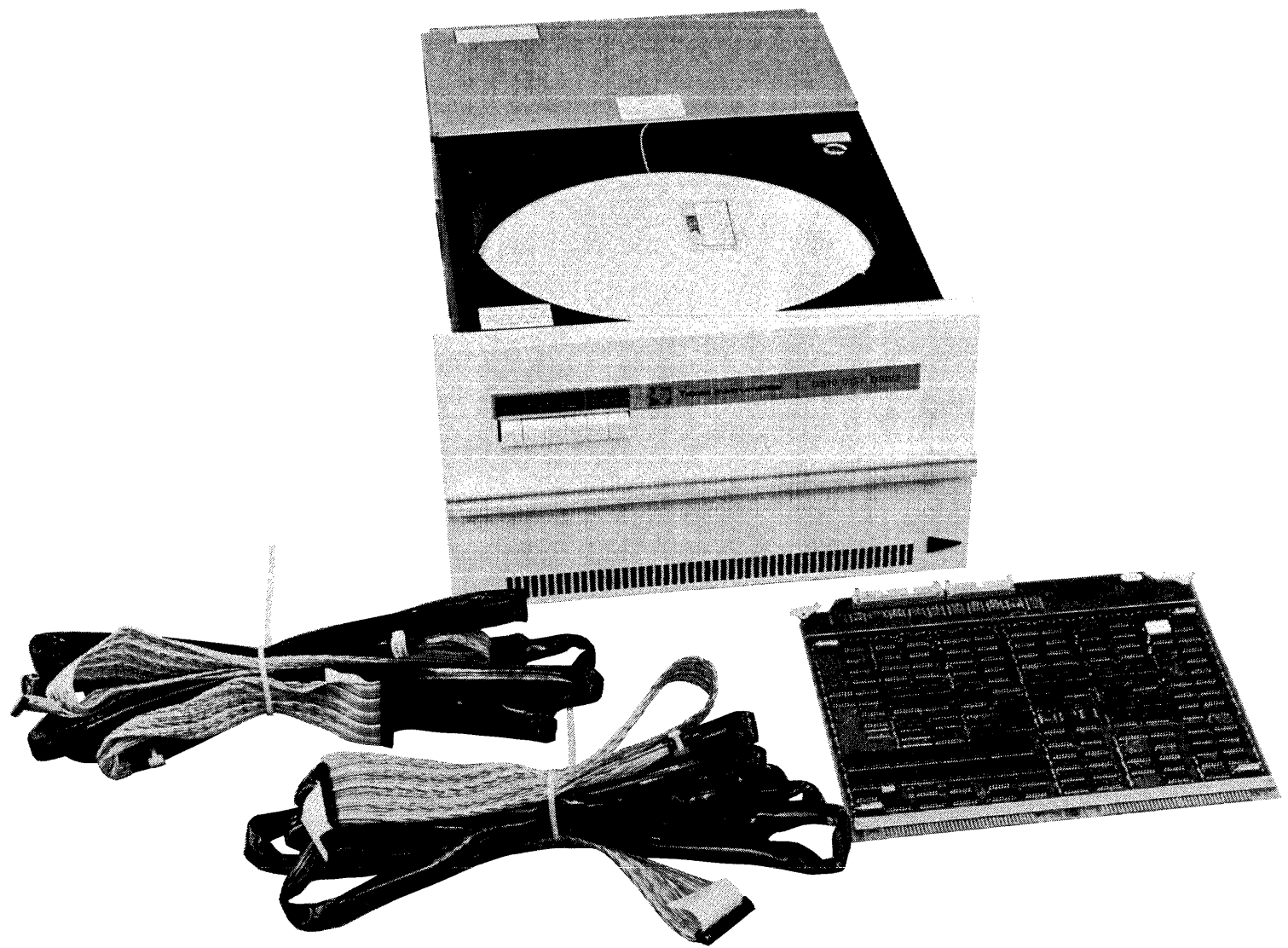

(A) 143663

Figure 1-1. Model DS10 Cartridge Disk System



SECTION 1

GENERAL DESCRIPTION

1.1 GENERAL

The Model DS10 Cartridge Disk System (Figure 1-1) is a moving-head random-access magnetic disk data storage system for the Model 990 Computer. The system consists of a printed wiring board disk controller and up to two Model DS10 Cartridge Disk Drives as shown in Figure 1-2. A Model DS10 Cartridge Disk System consisting of one disk controller and two disk drives is capable of storing 25.2 million unformatted bytes of data, 12.6 million per disk drive (20 million, 10 million per disk drive, when formatted).

The disk system features include:

- Single printed wiring board controller capable of supporting two disk drives.
- Transfer rate of 312K bytes per second
- A fixed and a removable disk
- Automatic track switching across head and cylinder boundaries
- Variable record formats, from one sector to full track
- Efficient disk formatting and double-frequency recording for high percentage use of storage
- Controller self-diagnostic capability

The Model DS10 Cartridge Disk System uses a magnetic medium-density (2200 bits per inch) disk (one fixed, one removable) and flying heads that move laterally over the disk surfaces to select different cylinders. Control for up to two disk drives resides on a disk controller printed wiring board (PWB) located in a Model 990 Computer chassis. The controller uses an on-board microprocessor to handle all time-critical events in the transfer of data between the computer and the disk drive. The disk drive assembly includes the mechanical, eletromechanical, and electronic components required to rotate the disks, perform track selection, and read and write data on the disk.

1.2 SYSTEM CONFIGURATION

Figure 1-2 illustrates the relationship of the major components of the Model DS10 Cartridge Disk System. The disk controller is a full-width PWB that is installed in the computer chassis to interface with the computer's high-speed TILINE* data bus.

Two cables are required to connect the controller to the primary disk drive. One cable carries control signals and serial data from the controller to the primary disk drive, and the other cable carries status signals and serial data from the primary disk drive to the disk controller. When a second disk drive is installed into a system, the disk drive is daisy-chained to the first disk drive with two additional cables. The cables that interconnect the two disk drives perform the same functions as the

*Trademark of Texas Instruments Incorporated.

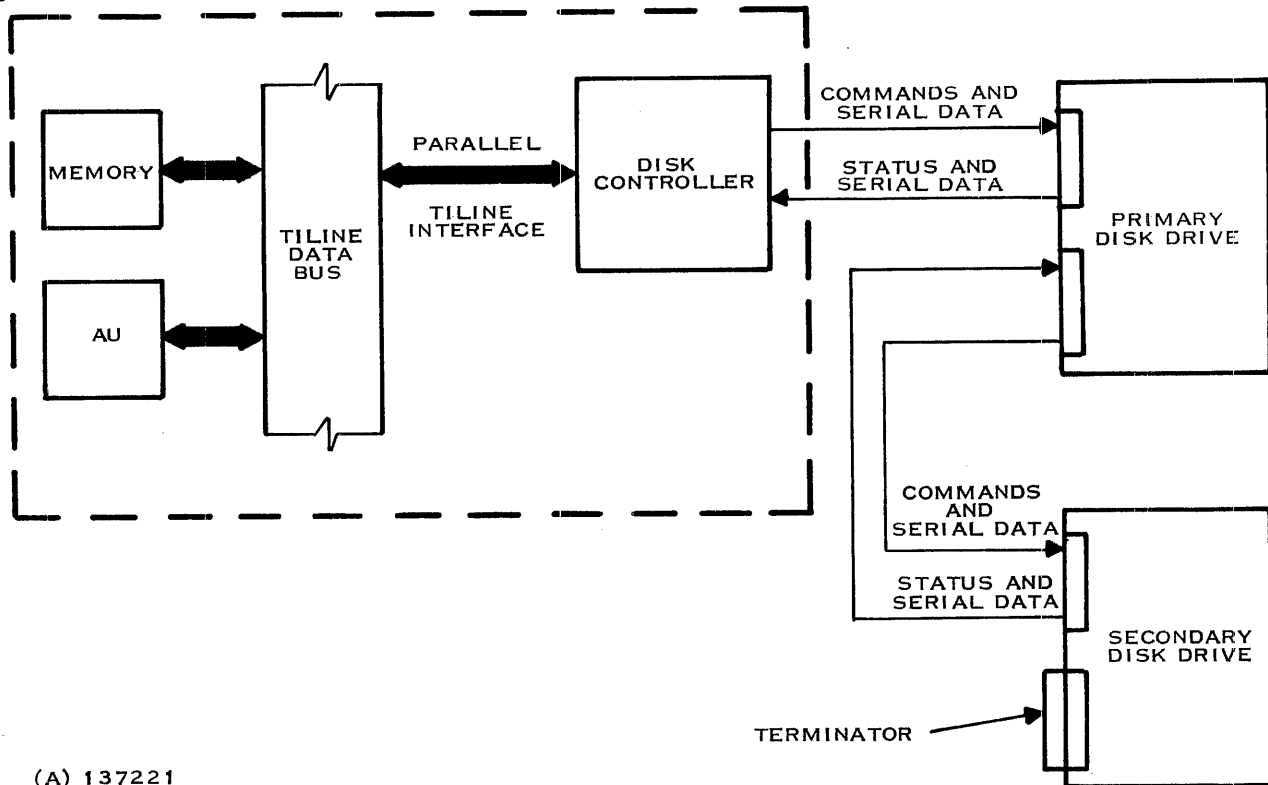

(A) 137221

Figure 1-2. Model DS10 Cartridge Disk Unit Subsystem Simplified Diagram

cables that interconnect the disk controller with the first disk drive. The second disk drive functions as though it were connected directly to a disk controller.

The cables connect to an adapter board at each disk drive. The adapter board mates the flat ribbon cable connectors to the Winchester connector on the disk drive.

1.2.1 TILINE BUS. The TILINE bus is an asynchronous, high-speed, 16-bit parallel data bus used to transfer data between the central processing unit (CPU) of the computer, the computer's memory, and any TILINE device installed in the computer, such as magnetic tape and disk storage systems. Any full-sized 990 circuit board plugged into the Model 990 Computer chassis may engage the TILINE bus and participate in data transfers. The TILINE bus is divided between two chassis connector slots, P1 and P2, in a full-width chassis slot.

Two classes of TILINE users interface with the TILINE bus. Users of the bus that contend for control of the bus are called TILINE masters, and users that only accept data from the bus are called TILINE slaves. The disk controller is both a master and a slave, depending on the operation being conducted. The disk controller is a slave when receiving commands from the CPU and a master when contending for the bus to transfer data to or from the computer's memory.

Data is transferred between the TILINE bus and the disk controller as parallel, 16-bit words. The associated address information is transferred as parallel, 20-bit words. In addition, a number of control lines are used to synchronize TILINE bus transfers and to indicate data parity errors. Figures 1-3 and 1-4 illustrate the timing relationship between the major signals on the TILINE interface. The signals in Figures 1-3 and 1-4 are described as follows:

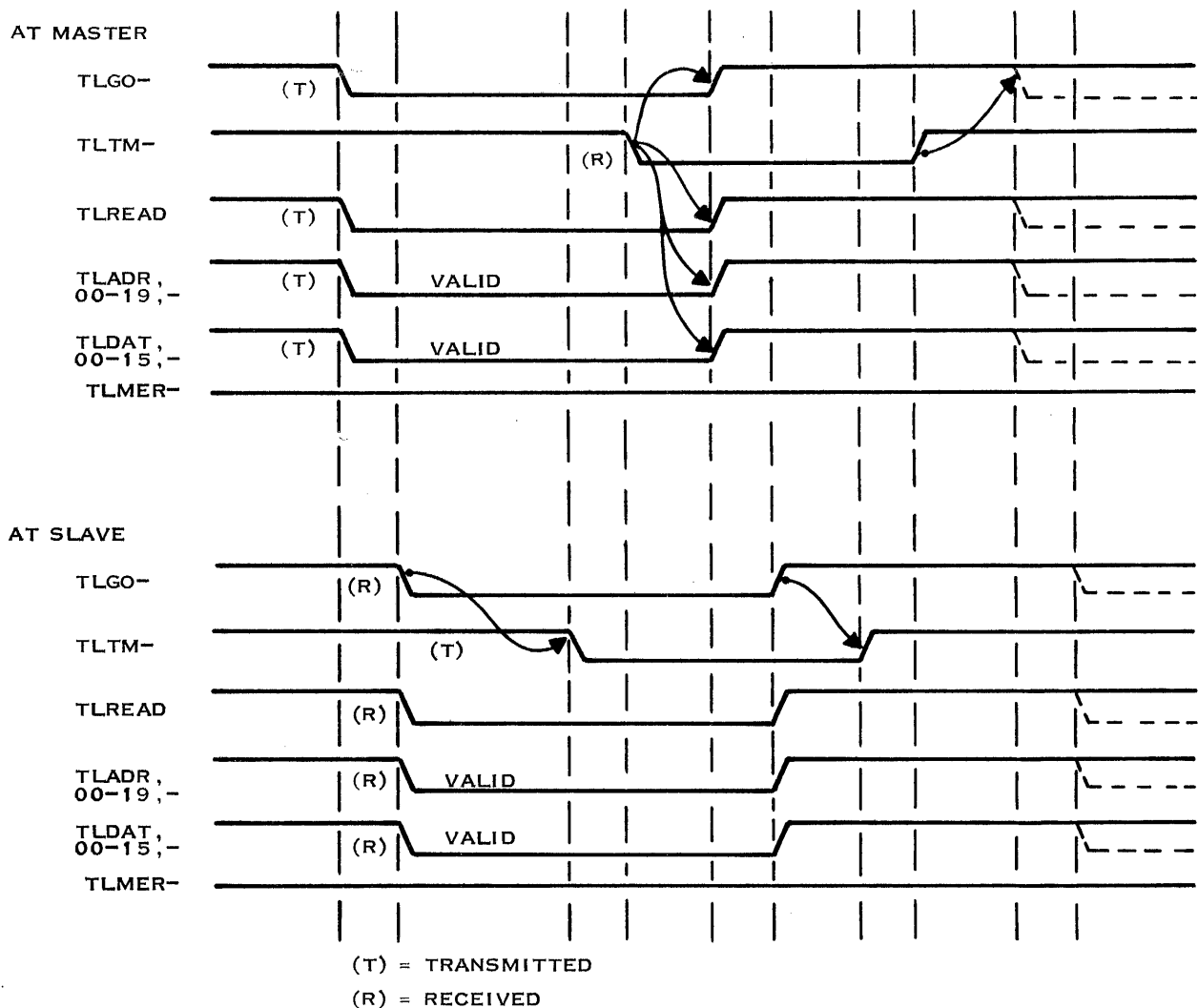

NOTE: TILINE DELAY IS EXAGGERATED FOR CLARITY

(A) 137222A

Figure 1-3. TILINE Master-to-Slave Write Cycle Timing

- **TILINE Go (TLGO-)** — a low-active, master-generated signal that alerts all slaves on the TILINE bus that a master is ready to initiate a data transfer. TLGO- directs all slaves to monitor the TILINE address (TLADR, 00-19) and respond when addressed. The master that generated TLGO- holds TLGO- low until the addressed slave responds with TILINE Terminate (TLTM-) or until the master times out.
- **TILINE Read (TLREAD)** — a high-active, master-generated signal that directs the addressed slave to fetch data from the addressed memory location and make the data available to the master that generated TLREAD. If TLREAD is low, the addressed slave is directed to store in the slave's addressed memory location the data that the master has made available on the interface.

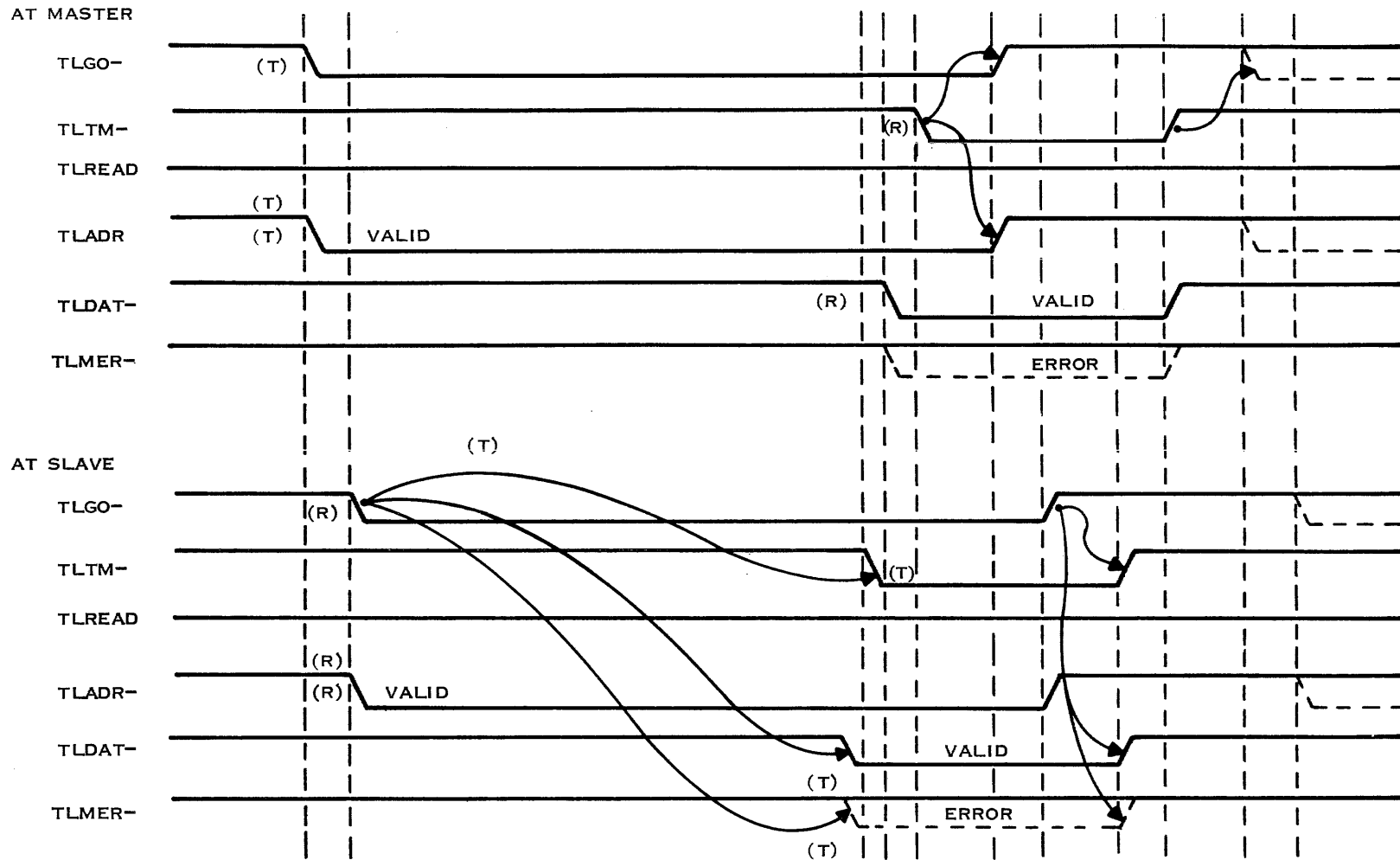

(T) = TRANSMITTED

(R) = RECEIVED

NOTE: TILINE DELAY IS EXAGGERATED FOR CLARITY

(A) 137223A

Figure 1-4. TILINE Master-to-Slave Read Cycle Timing



- *TILINE Terminate (TLTM-)* — a low-active, slave-generated signal that informs the master that generated TLGO- that the slave has accepted the master's data during a memory write or that the slave's memory data is valid on the interface as TILINE Data (TLDAT, 00-15). The slave that generated TLTM- holds TLTM- low until the master removes TLGO-.
- *TILINE Address (TLADR, 00-19-)* — 20 low-active, master-generated signals that address the slave memory location to be accessed for the read or write operation.
- *TILINE Data (TLDAT, 00-15-)* — 16 low-active master- or slave-generated signals that provide two-way data transfer over the TILINE interface.
- *TILINE Memory Error (TLMER-)* — a low-active, slave-generated signal that informs the master that the active slave detected a parity error when data was fetched from the slave's memory. The slave performs no parity check on data fetched from its registers.

1.2.2 DISK CONTROLLER. The disk controller is a microprocessor-based controller with a set of control ROMs (read only memories) implemented on a full-sized Model 990 PWB. The disk controller can be installed into any standard TILINE chassis slot. The controller slave address is set by switches located on the controller PWB as described in Section 2. The disk controller supports up to two disk drives connected as shown in Figure 1-5.

All disk controller operations are initiated by instructions (commands) from the computer. These instructions are directed to the slave address assigned to the controller.

After a disk controller command has been initiated by the computer, the computer cannot read or write to the slave address of the designated controller until the command is completed. When the controller is busy and a slave request is initiated, the request is terminated normally and the idle bit is forced to zero.

After initiation of a command by the computer, the disk controller may become a TILINE master. The controller contends for TILINE access on a positional priority basis by cycle-stealing with the CPU and with any other TILINE master devices that are active. After gaining access to the TILINE bus, the disk controller transfers 16-bit parallel data words to and from the slave it has addressed (in most cases, a computer memory module). The disk controller is autonomous (not dependent on any CPU action after it has been activated).

Figure 1-6 shows the disk controller (PWB) and Figure 1-7 shows the disk controller (fine line PWB).

1.2.3 DISK DRIVES. The Model DS10 Cartridge Disk Drive (Figures 1-1 and 1-2) is a voice coil-actuated disk drive with four moving heads (two each for a fixed and a cartridge disk). The disk drive assembly contains the read/write heads, voice coil, analog and digital circuit boards, power supply, power amplifier, cartridge receiver, spindle and drive motor, one fixed disk, filter, air blower and cooling system.

The disk drive operates at 2400 revolutions per minute (rpm) and has an unformatted storage capacity of 100 million bits of data. Each drive contains one fixed disk and accepts a removable cartridge to double its storage capacity. The disk drive is available for slide mounting in a standard 482.60-millimeter (19.00-inch) rack with 266.70 millimeters (10.50 inches) of panel space (Figure 1-1) or mounted in its own standalone cabinet (Figure 1-8). Table 1-1 lists the performance characteristics of the disk drive.

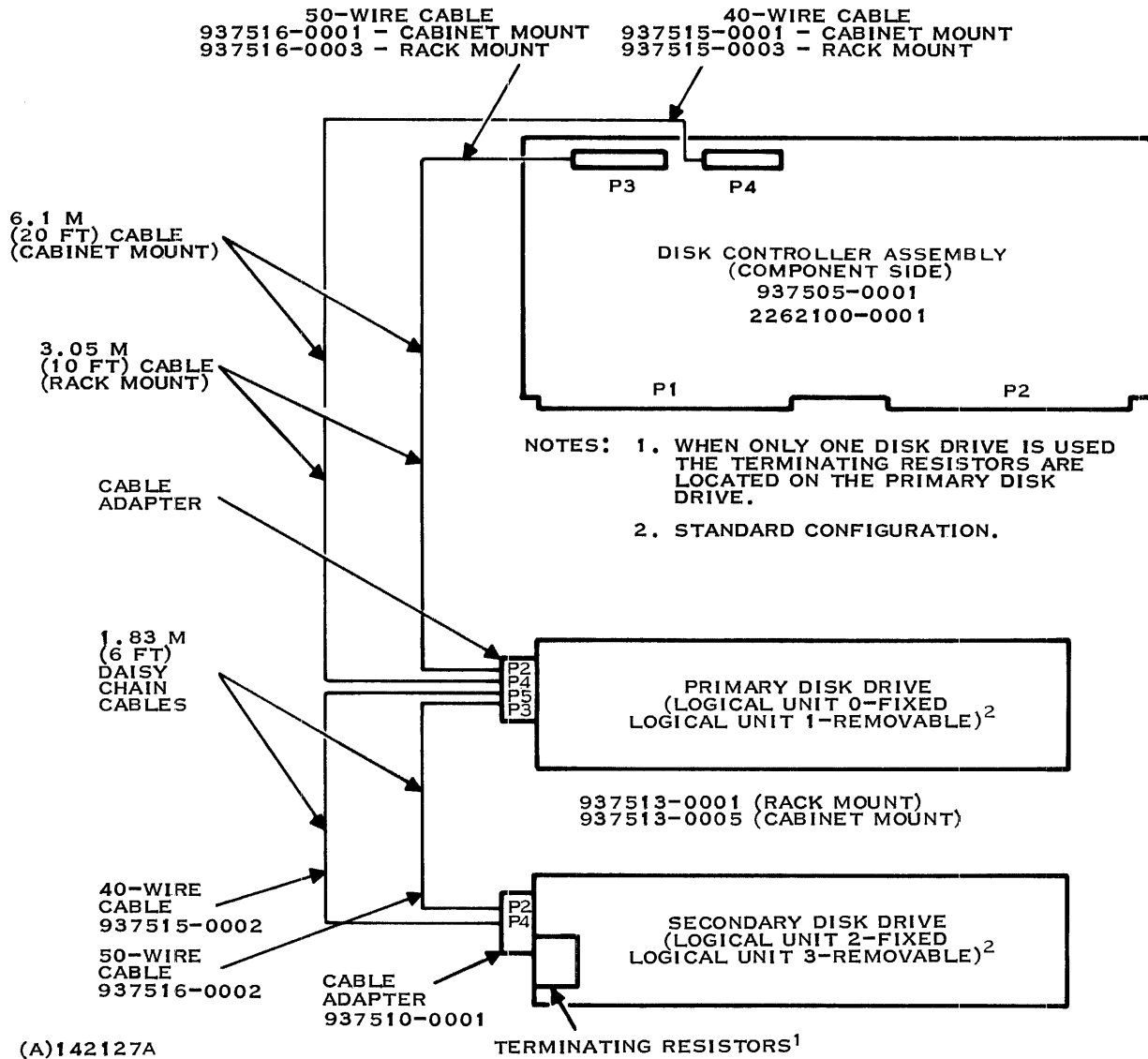

Figure 1-5. Interconnection of Disk Controller and Two Disk Drives

1.3 SYSTEM OPERATION

The Model DS10 Cartridge Disk System provides an auxiliary mass storage facility for the Model 990 Computer system. The disk system performs disk-to-memory transfers between TILINE memory and disk memory. The data transfer, whether read or write, is initiated by software executing in the computer's central processing unit (CPU) and controlled by firmware executing in the microprocessor of the disk controller after receipt of a command from the computer.

The computer addresses the disk system via the disk controller's slave address. The disk controller then functions as a TILINE master and relieves the computer of direct responsibility for the data transfer. The disk controller fetches parallel data from TILINE memory (write) or transfers serial data from disk (read); converts the data to serial or parallel, depending upon the direction of the data transfer; and completes the transfer. The disk operates under complete control of the disk controller.



946261-9701

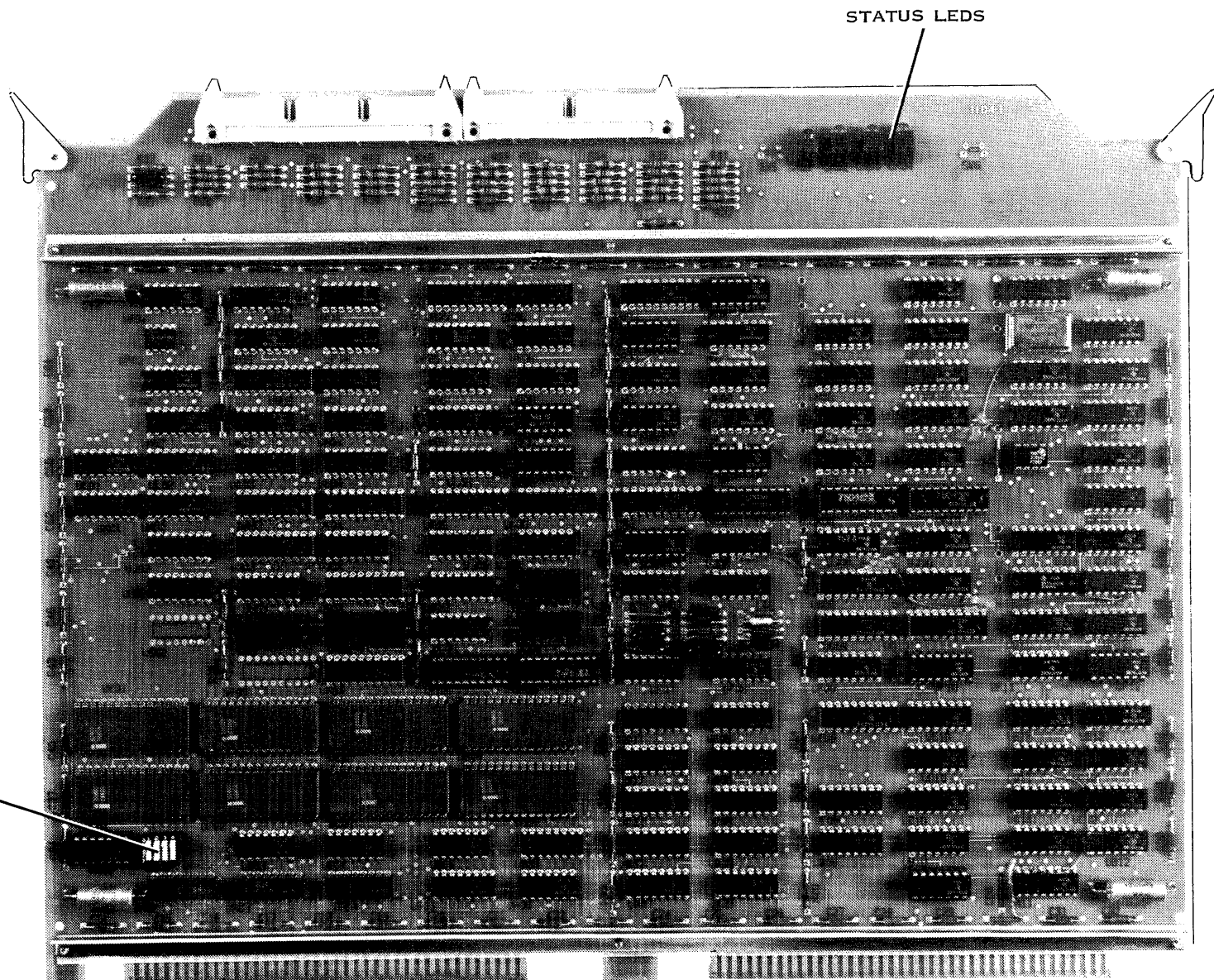

SLAVE ADDRESS SWITCHES

STATUS LEDS

(A)137249A

Figure 1-6. Model DS10 Cartridge Disk Controller (PWB)



946261-9701

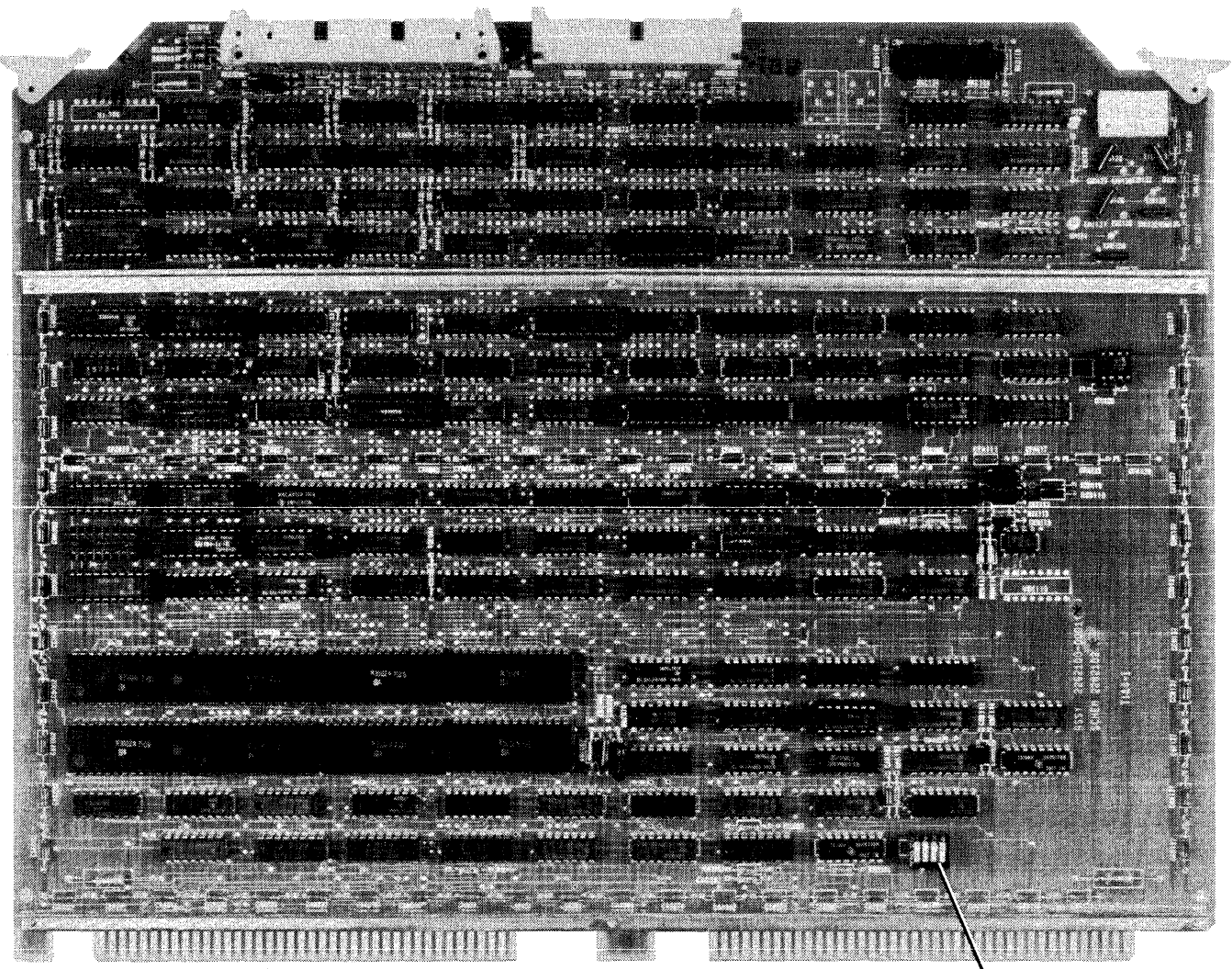

SLAVE ADDRESS SWITCHES

(A) 143664

Figure 1-7. Model DS10 Cartridge Disk Controller (Fine Line PWB)

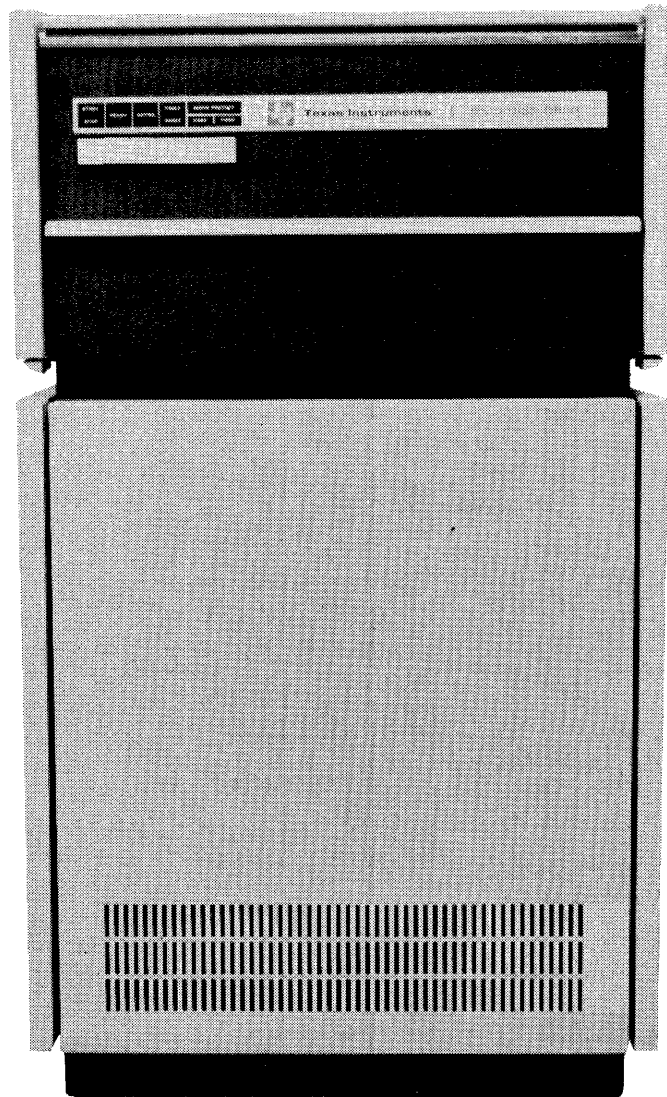

(A) 143665

Figure 1-8. Model DS10 Cartridge Disk Drive (Cabinet Mount)



Table 1-1. Disk Drive Specifications

Item	Specification
Spindle speed	2400 rpm with $\pm 2\%$ speed variation with input frequency ± 0.5 hertz and input voltage $+10\% - 15\%$
Tracks per surface	408, numbered 0 through 407
Tracks per drive	1,632
Tracks per cylinder*	2 on each of two disks
Sectors per drive	32,640
Sectors per track	20
Heads per cylinder*	2
Heads per drive	4
Recording surfaces per drive	4
Recording mode	Double frequency
Track density	200 tracks per inch
Recording density	1524 bits per inch (outer track) 2200 bits per inch (inner track)
Bits per disk drive	50,000,000 nominal
Bits per cylinder	250,000 nominal
Bits per track	62,500 nominal
Bits per sector	3,125
Capacity (unformatted)	12.6 megabytes
Words per sector	144
Format overhead	48 words
Bit rate	2.5 megahertz
Average access time	35 milliseconds
Average latency time	12.5 milliseconds
Track-to-track access time	7 milliseconds
Maximum access time	60 milliseconds

NOTE: *A cylinder of storage consists of 2 tracks on either the removable cartridge or the fixed disk. The cartridge and the fixed disk are separate logical units, although they share a common spindle and a common head carriage; therefore, a cylinder does not cross disk boundaries.

In a system with one disk controller and two disk drives, the disk controller functions as though only one disk drive with more storage space were attached. All operations for different disk drives are identical except for the unit select signal used to identify the drive being addressed.

1.4 SYSTEM SPECIFICATIONS

Table 1-2 lists the physical and electrical characteristics for the disk system.



Table 1-2. General Characteristics of Model DS10 Cartridge Disk System

Item	Description
Controller physical dimensions	361.95 × 266.70 × 12.70 millimeters (14.25 × 10.50 × 0.50 inches)
Disk drive physical dimensions	See Figures 1-9 and 1-10
Ac power requirements (disk drive)	See Table 1-3
Dc power requirements (disk controller)	+5 Vdc @ 5.5 amperes -12 Vdc @ 0.03 ampere
Operating temperature	16° to 32°C (60° to 90°F) with a maximum gradient of 6.7°C (12°F) per hour
Operating humidity	10 to 90% relative with no condensation
Heat generated by disk drive	1050 BTU/hr

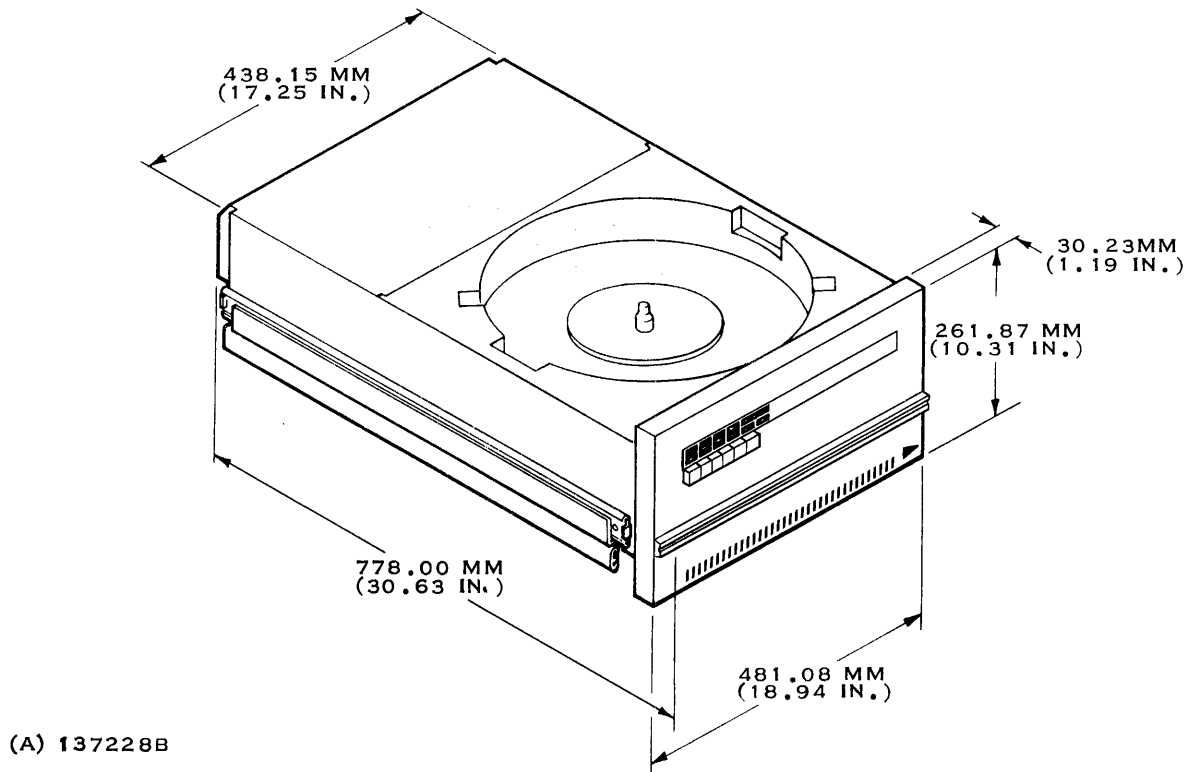
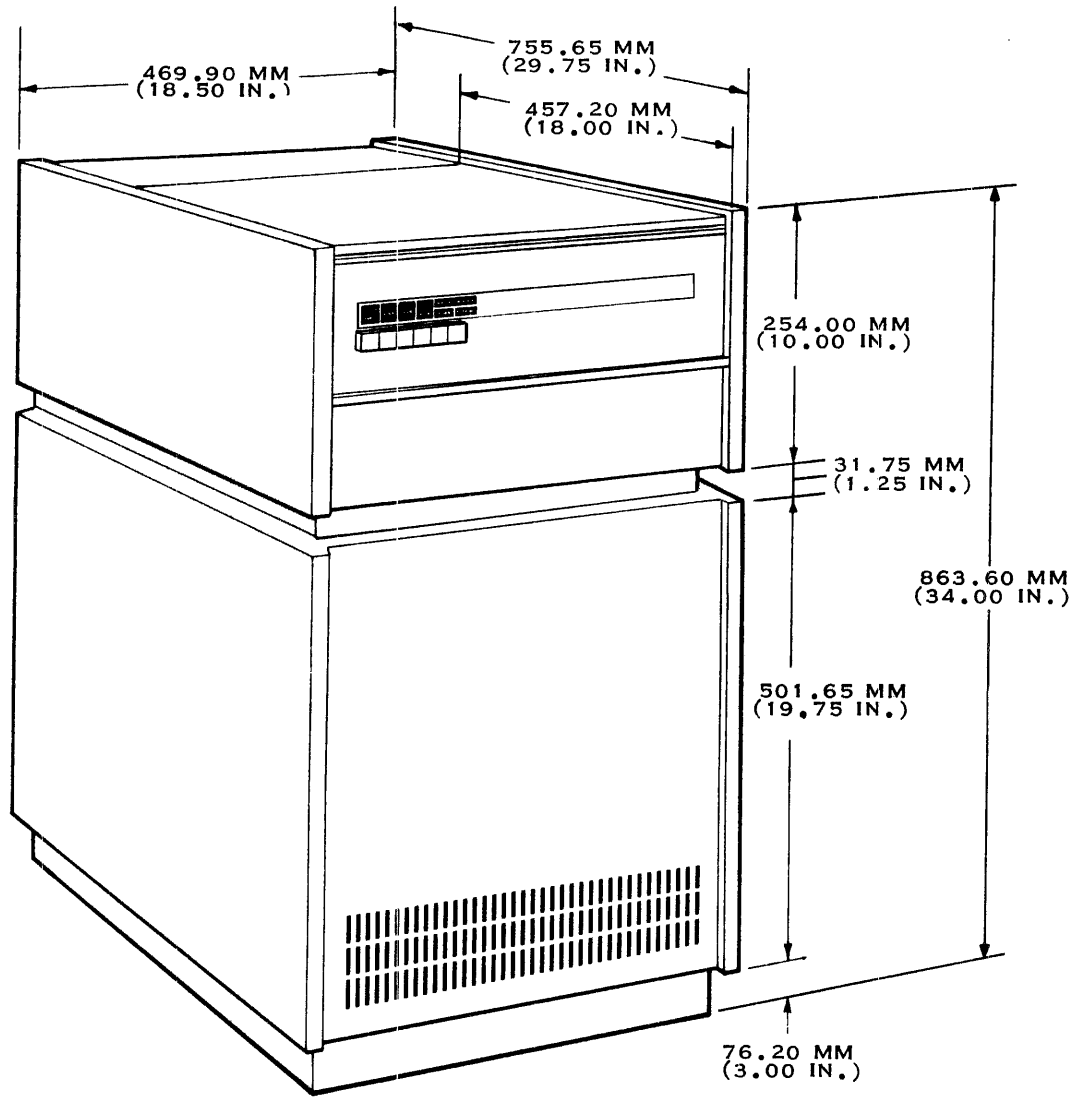

Figure 1-9. Rack Mount Disk Drive Physical Dimensions



(A) 137229B

Figure 1-10. Cabinet Mount Disk Drive Physical Dimensions



**Table 1-3. Ac Power Requirements
for Disk Drive (Both 50- and
60-Hertz Drives)**

Voltage (Vac)	Operating Current (Amperes)
100	5.6
110	5.0
120	4.6
130	4.3
140	4.0
150	3.8
160	3.6
170	3.3
180	3.2
190	3.0
200	2.9
210	2.7
220	2.6
230	2.5
240	2.4
250	2.3

NOTE: Frequency must be maintained at ± 0.5 hertz tolerance. Start current is two times rating for each drive and lasts for five seconds.



SECTION 2

INSTALLATION

2.1 GENERAL

This section contains information for unpacking and inspecting a Model DS10 Cartridge Disk System, and installing the system as a part of a Model 990 Computer system. Information is also provided to ensure that the site for the installation is properly prepared prior to installation of the disk system.

The user should read this entire section before proceeding with the installation. Circumstances that are unique to the user's site may dictate that the installation procedures be performed in a different order from that set forth in this section. Familiarity with the entire installation procedure will provide a basis for planning the task before starting.

CAUTION

Do not connect or disconnect any plug or circuit board when power is applied, as voltage transients may damage electronic parts.

The expansion guidelines for the disk system allow daisy-chaining two disk drives from one disk controller as described in Section 1. Available kit options are:

- Complete single-disk drive system — includes disk controller, disk controller-to-disk drive interface cables, adapter board, and one disk drive
- Disk controller only — includes disk controller and disk controller-to-disk drive interface cables with adapter board
- Primary disk drive — includes one disk drive
- Secondary disk drive — includes one disk drive, disk drive-to-disk drive interface cables, and adapter board.

NOTE

All of the above options are available with rack- or cabinet-mount disk drives for operation on 110-volt, 60-hertz and 100-volt or 230-volt, 50-hertz operation. Other voltage and frequency options must be set during installation.

Major system components, along with their associated part numbers, are listed in Table 2-1. Kit components and additional options, along with the assembly part numbers and purchase price, may be obtained from Texas Instruments Incorporated upon request. Components of a typical disk system are shown in Figure 2-1.

Interrupt level assignments are required to interface the disk controller to the Model 990 Computer's TILINE bus. These connections are made at the factory before shipment for a standard configuration and installation. However, if necessary, the user may assign new interrupts



Table 2-1. Model DS10 Cartridge Disk System Components

Component	Part Number
Model DS10 disk controller (PWB)	937505-0001
Model DS10 disk control (fine line PWB)	2262100-0001
Model DS10 disk drive, rack mount	937513-0001
Model DS10 disk drive, cabinet mount	937513-0005
Disk cartridge	937507-0001
40-pin, 6.10-meter (20-foot) bus cable assembly	937515-0001
50-pin, 6.10-meter (20-foot) bus cable assembly	937516-0001
Cable adapter	937510-0001
40-pin, 1.83-meter (6-foot) daisy chain cable assembly	937515-0002
50-pin, 1.83-meter (6-foot) daisy chain cable assembly	937516-0002
40-pin, 3.05-meter (10-foot) bus cable assembly	937515-0003
50-pin, 3.05-meter (10-foot) bus cable assembly	937516-0003

to suit his needs. If new interrupts are required, these assignments and connections must be made during installation.

Also, the following operations must be performed during installation:

- TILINE address switches on the disk controller must be set to the slave address that the software is to recognize.
- The disk controller must be assigned to a permanent location (slot) in the computer chassis.
- Daisy-chained disk drives must have their unit designations (0 or 1) set by jumpers on the disk drive.

2.2 SITE REQUIREMENTS

Certain conditions are prerequisite for installation of a disk system including physical space for the disk drive, power for the disk drive, a Model 990 Computer with 12K memory, and an available TILINE chassis slot.

2.2.1 MOUNTING SPACE REQUIREMENTS FOR RACK MOUNT DISK DRIVE. The disk drive is available for mounting in a standard 482.60-millimeter (19-inch) (RETMA) rack. If the rack for the disk drive is stationary, approximately 610 millimeters (24 inches) must be provided between the rear of the rack and any stationary objects (walls, racks, etc.) to permit personnel access for cable connection or maintenance. If the rack is movable, sufficient space must be provided for the rack to be moved away from any stationary objects far enough for personnel to have access to the rear of the rack for cable connection or maintenance. If the rack is movable, sufficient cable slack to provide the necessary movement must be planned in advance of the installation. Approximately 762 millimeters (30 inches) must be provided between the front of the rack and any stationary objects so that personnel can slide the disk drive out of the rack for maintenance and install and/or remove the disk drive. Figure 2-2 shows the recommended dimensions for rack mounting the disk drive.

2.2.2 MOUNTING SPACE REQUIREMENTS FOR CABINET MOUNT DISK DRIVE. The disk drive is available in a self-contained cabinet. The cabinet is movable, so sufficient space must be provided for the cabinet to be moved away from any stationary objects far enough for personnel to have access to the rear of the cabinet for cable connection or maintenance. Sufficient cable slack must also be provided to allow the necessary movement.



946261-9701

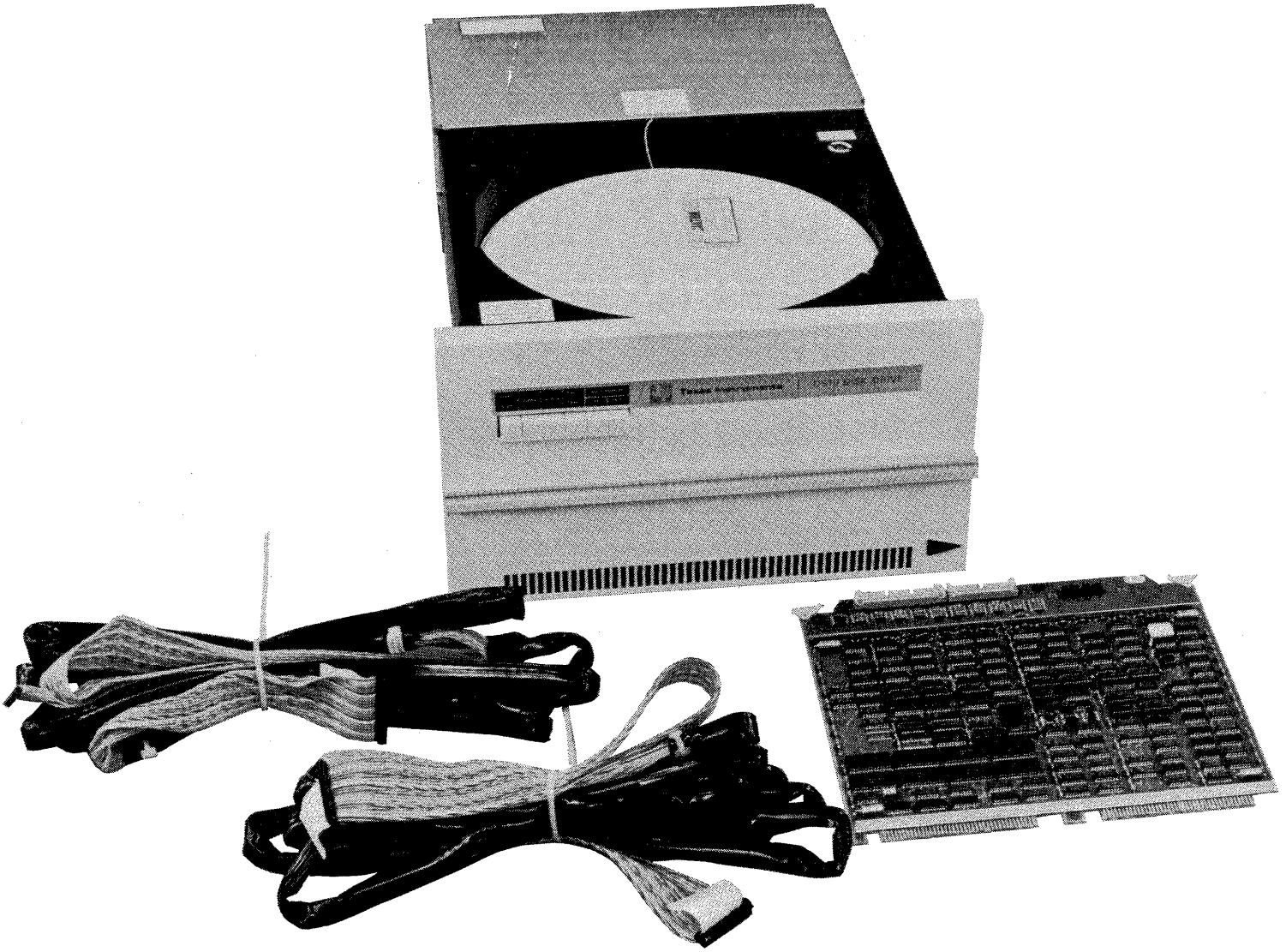

(A) 143663

Figure 2-1. Model DS10 Cartridge Disk System Components

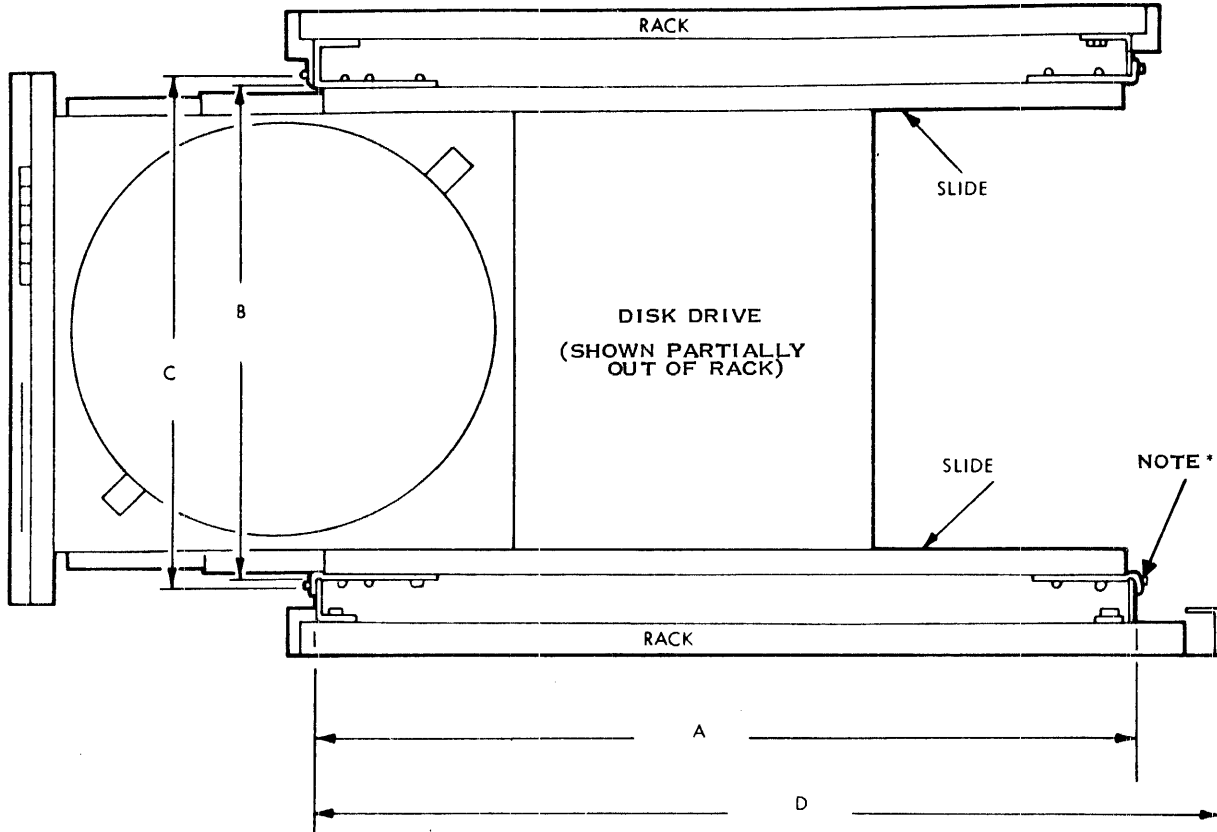

NOTE * IF THE DRIVE IS MOUNTED IN A CABINET WITH A COMPUTER CHASSIS THE DIMENSION FOR "A" IS 622.3 MILLIMETERS (24.5 INCHES). THIS DIMENSION CAN BE ACCOMPLISHED BY REVERSING ONE OF THE SLIDE MOUNTING BRACKETS. (SEE FIGURE 2-21)

A. DISTANCE FROM FRONT MOUNTING RAILS TO REAR MOUNTING RAILS.	546.10 TO 590.55 OR 704.85 TO 755.65 MM (21.50 TO 28.25 OR 27.75 TO 29.75 IN.)
B. MINIMUM CLEARANCE BETWEEN MOUNTING RAILS (FRONT AND REAR).	446.02 MM (17.56 IN.)
C. DISTANCE BETWEEN MOUNTING HOLES (FRONT AND REAR).	453.64 TO 471.42 MM (17.86 TO 18.56 IN.)
D. MINIMUM LENGTH OF CABINET FROM FRONT MOUNTING RAILS (CABLE AND CONNECTOR CLEARANCE).	764.54 MM (30.10 IN.)

(A) 137231B

Figure 2-2. Recommended Rack Dimensions for Model DS10 Cartridge Disk Drive



Space must be provided at the sides of the cabinet for maintenance personnel to stand while working on the drive. Figure 2-3 shows the physical dimensions of the cabinet.

2.2.3 AC POWER REQUIREMENTS. The disk system can be ordered configured for operation from 100 or 110 volts, 60 hertz or 100 or 230 volts, 50 hertz. Any of the voltage/frequency combinations listed in Table 1-3 may be selected by following the conversion procedure included in the installation procedure. Prior to installation, the site must be prepared to provide the necessary voltage and current required by the disk drive configuration.

2.2.4 MODEL 990 COMPUTER. The Model DS10 Cartridge Disk System requires a Model 990 Computer with TILINE, an available full-width TILINE chassis slot, and a software operating system. These must either be ordered with the disk system or provided at the site prior to installation of the disk system.

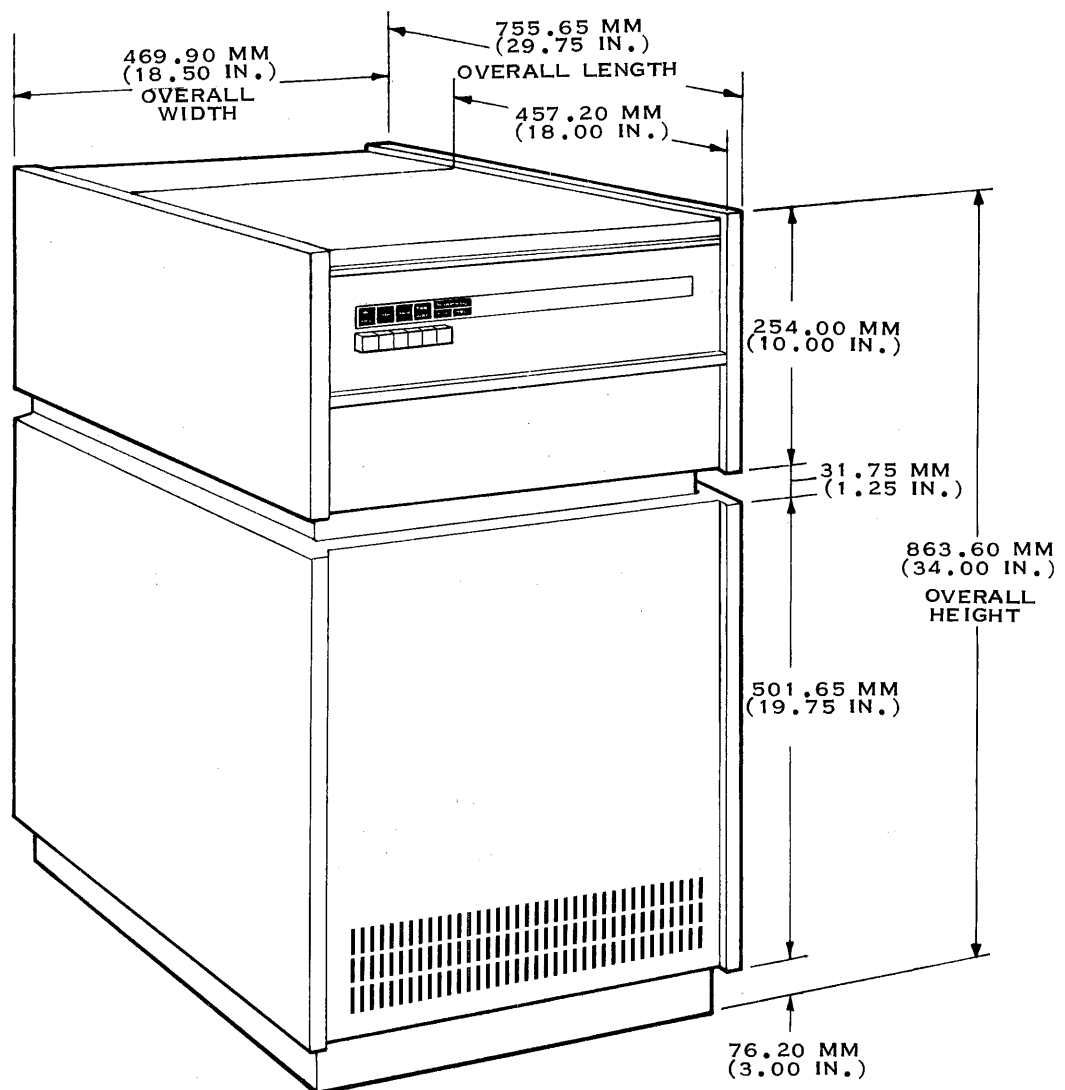

(A) 137232B

**Figure 2-3. Physical Dimensions of Cabinet Mount
Model DS10 Cartridge Disk Drive**



Table 2-2. Site Environmental Requirements for Model DS10 Cartridge Disk System

Item	Requirement
Temperature	16° to 32°C (60° to 90°F) with a maximum gradient of 6.7°C (12°F) per hour
Humidity	10 to 90% relative with no condensation
Altitude	-305 to 3048 m (-1000 to 10,000 ft.)
Pressure	1060 to 660 millibars = 793 to 513 mm (31.2 to 20.2 in.) Hg with maximum gradient of 5 mm Hg

2.2.5 SUPPORTIVE ENVIRONMENT. Table 2-2 lists the parameters for a supportive operating environment for the disk system. Prior to installation, it must be ensured that the site meets the requirements.

2.2.6 CABLING RESTRICTIONS. Cable lengths affect the positioning of the equipment at the site. The primary disk drive must be positioned so that the 6.10-meter (20-foot) interconnection cables (cabinet mount) or 3.05-meter (10-foot) interconnection (rack mount) may be connected to both the disk drive and computer, and be routed along a convenient out-of-the-way path; they must have sufficient slack at either end to provide access for maintenance and installation. In like manner, the secondary disk drive, if used, must be positioned so that the 1.83-meter (6.00-foot) cables may be connected to both disk drives, and be routed along a convenient out-of-the-way path; they also must have sufficient slack at either end to provide access for maintenance and installation.

2.3 UNPACKING INSTRUCTIONS

The disk drives are shipped in containers as shown in Figures 2-4 and 2-5. If the disk drive is received at the same time as the computer system, the disk controller, interconnection cables, and technical manuals may be packed with the computer. Otherwise, these items are packaged in a polyethelene bubble pack and ethafoam in the accessory package shown in Figure 2-4 (for rack mount) or in a separate package for the configuration shown in Figure 2-5.

2.3.1 UNPACKING RACK MOUNT DISK DRIVE. Upon receipt of the container, inspect the container to ensure that no physical damage occurred during shipment. If damage is apparent, notify carrier immediately.

WARNING

The unpacked rack mount disk drive weighs approximately 67 kilograms (148 pounds). When unpacked, handling of the unit requires assistance by another person or use of a portable hoist or hydraulic lift, to avoid the possibility of back strain.

NOTE

Save all shipping materials except where noted for use in reshipment of unit.

After ensuring that no damage has been done to the container or its contents during shipping, unpack the disk drive according to the following instructions:

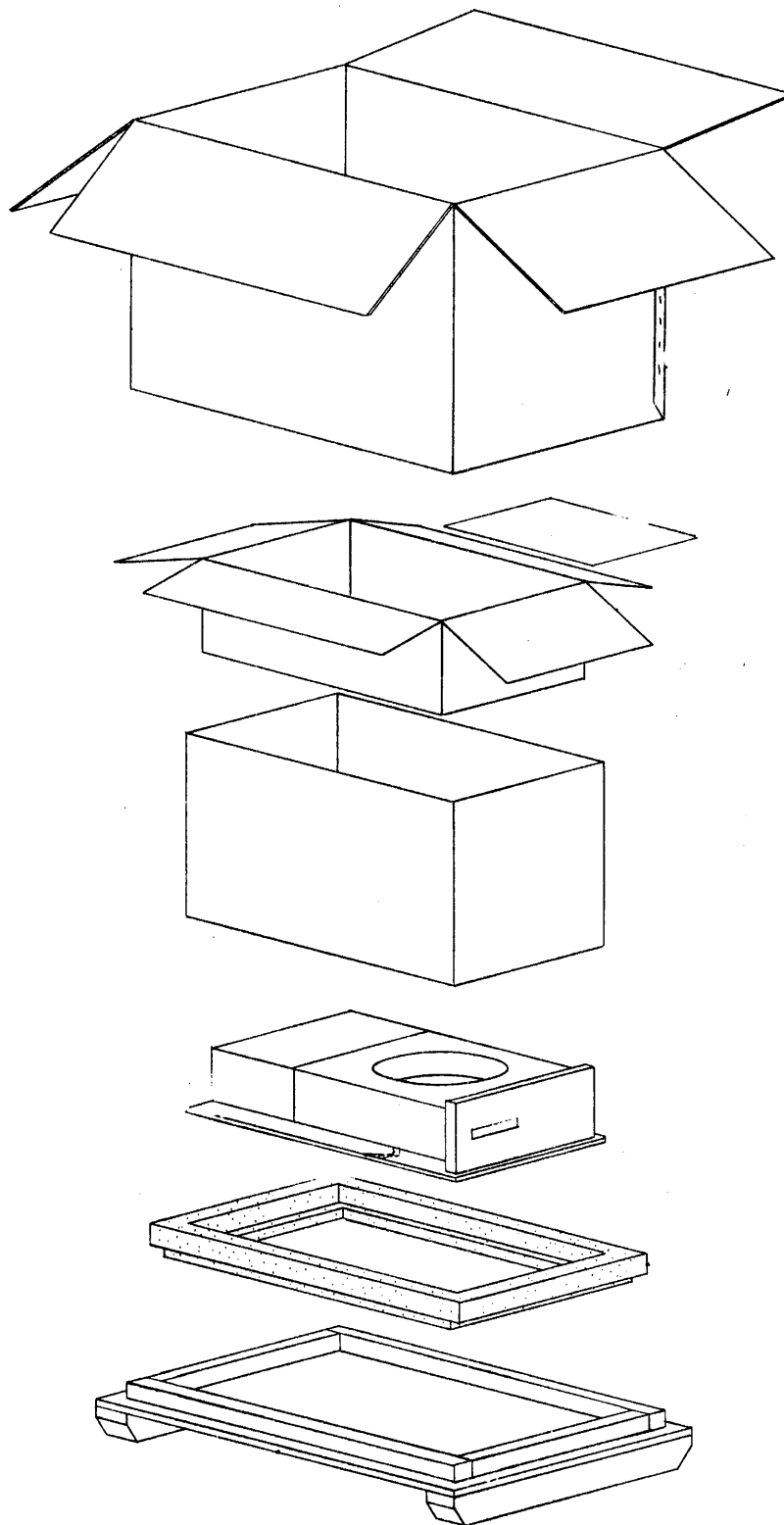

(A) 137233

Figure 2-4. Rack Mount Disk Drive Shipping Configuration

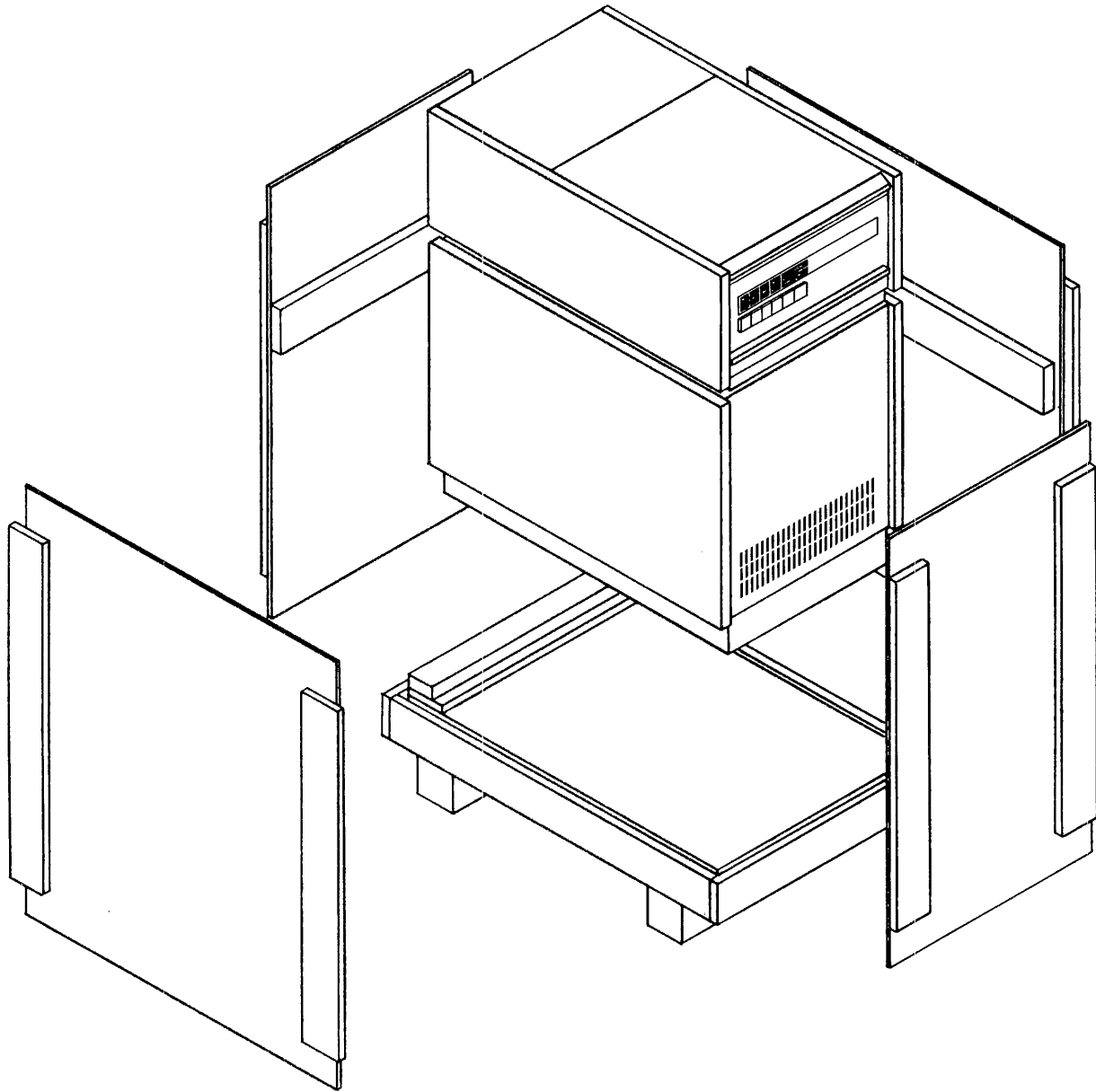

(A) 137234 A

Figure 2-5. Cabinet Mount Disk Drive Shipping Configuration

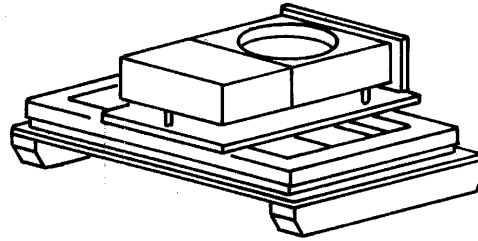

(A) 137235

Figure 2-6. Placement of Disk Drive for Shipping Bolt Removal

1. Position container so that address label is upright.
2. Cut and discard metal bands around shipping container.
3. Open top flaps of shipping container and lift shipping container by flaps up and off assembly.
4. Remove manual from top of accessory package and read unpacking instructions.
5. Grasp accessory package by its sides, lift it out of inner tube, and set it aside.
6. Lift cardboard inner tube off disk drive and set aside.

WARNING

The following step requires at least two persons.

7. Grasp disk drive by placing fingers underneath sides of unit and lift clear of foam base. Rotate unit 90 degrees as shown in Figure 2-6 and set unit on foam base to expose mounting bolt heads underneath wood base.
9. Open plastic bag surrounding disk drive; press bag down around disk drive sides. Unit can now be lifted free of wood base and plastic protective bag.
10. Remove three screws (Figure 2-7) that hold electronics cover in place and remove electronics cover.
11. Remove carriage lock pin (Figure 2-8) by rotating head of pin 90 degrees counterclockwise and pulling straight up. Store pin on side of magnet as shown in Figure 2-8.

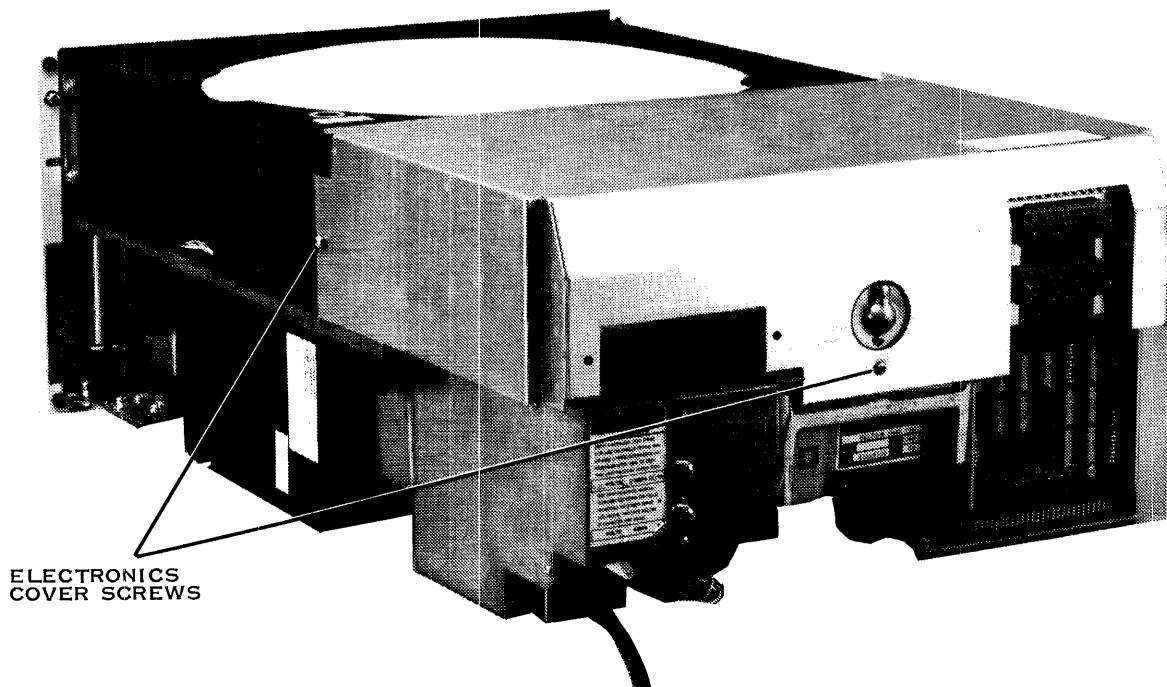

(A) 137236 (990-1077-15-5)

Figure 2-7. Location of Electronics Cover Screws

12. Press in on outboard end of card cage cover clamp (Figure 2-9) and move clamp end forward until free of screw. Lift up on free end of clamp to release end hooked onto inboard side of card cage.
13. Lift card cage cover off and set aside.

NOTE

Refer to Figure 2-10 for steps 14 through 23.

NOTE

The following steps are necessary only if a problem occurs during installation.

14. Remove control PWB and verify that S1 settings are as shown in Figure 2-11.
15. Replace control PWB.
16. Remove sector PWB and verify that switch settings are as shown in Figure 2-12.
17. Replace sector PWB.
18. Remove servo PWB and verify that switch settings are as shown in Figure 2-13.

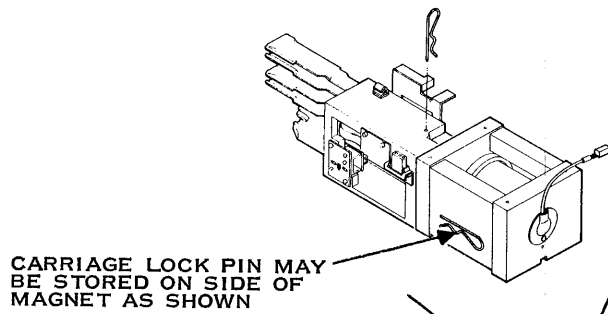
**TO INSTALL:**

INSERT STRAIGHT LEG OF PIN INTO SMALL HOLE IN ACTUATOR FRAME, TWIST 90° COUNTERCLOCKWISE, PRESS DOWN, AND ALLOW PIN TO RETURN TO NORMAL POSITION.

TO REMOVE:

TWIST 90° COUNTERCLOCKWISE AND PULL UP.

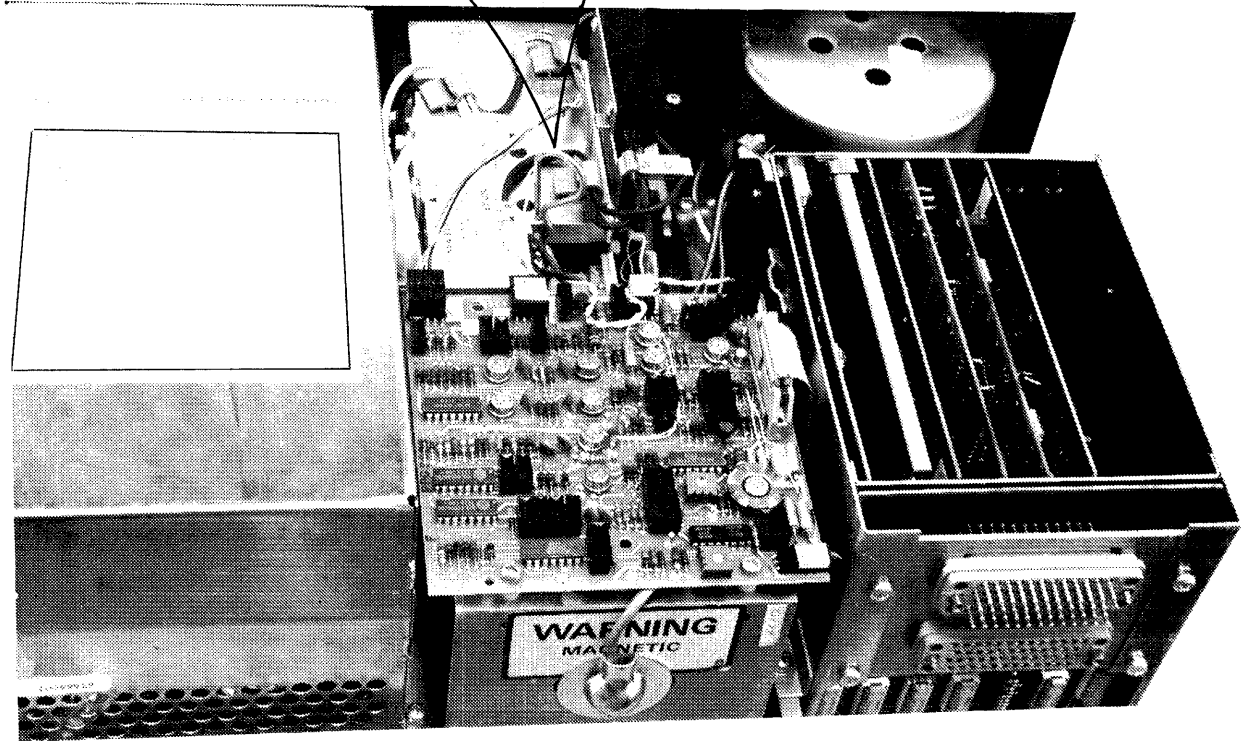

(A) 137237 (990-977-35-11)

Figure 2-8. Carriage Lock Pin Location

19. Replace servo PWB.
20. Remove data recovery PWB and verify that switch settings are as shown in Figure 2-14.
21. Replace data recovery PWB.
22. Remove r/w/e PWB and verify that resistor modules are in orientation shown in Figure 2-15.
23. Replace r/w/e PWB.

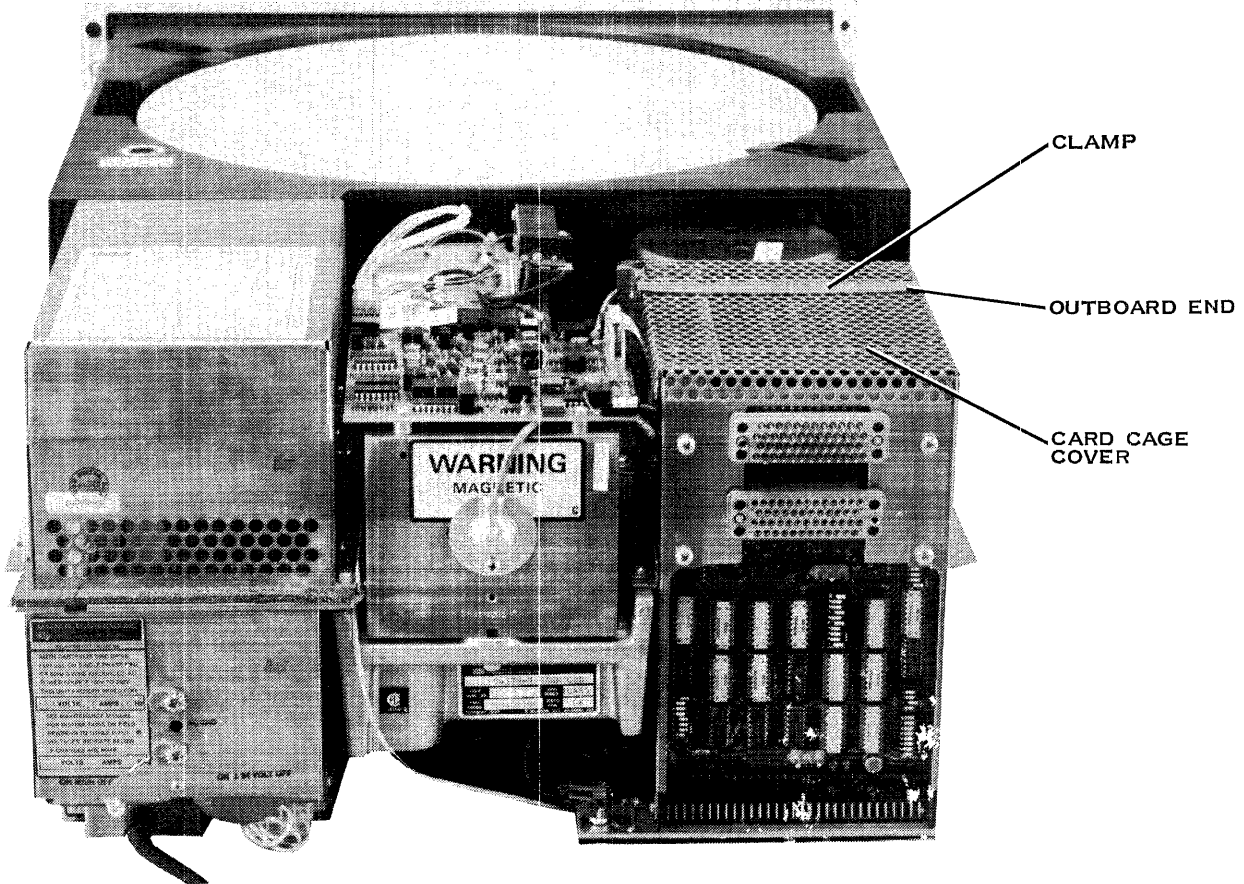

(A)137238A

Figure 2-9. Card Cage Cover and Clamp Location

24. Replace card cage cover and clamp.
25. Reinstall electronics cover. Disk drive is now ready for attachment of slides.

2.3.2 UNPACKING DISK CONTROLLER. The disk controller is packaged in the special two-piece ethafoam package shown in Figure 2-16. For the rack mount disk drive, the controller is shipped inside the accessory package shown in Figure 2-4. For the cabinet mount disk drive, the controller is shipped in a separately shipped accessory package similar to the one for the rack mount disk drive. The unpacking procedures for the controller are the same for all configurations once the accessory package has been separated from the rest of the shipping materials. The instructions are as follows:

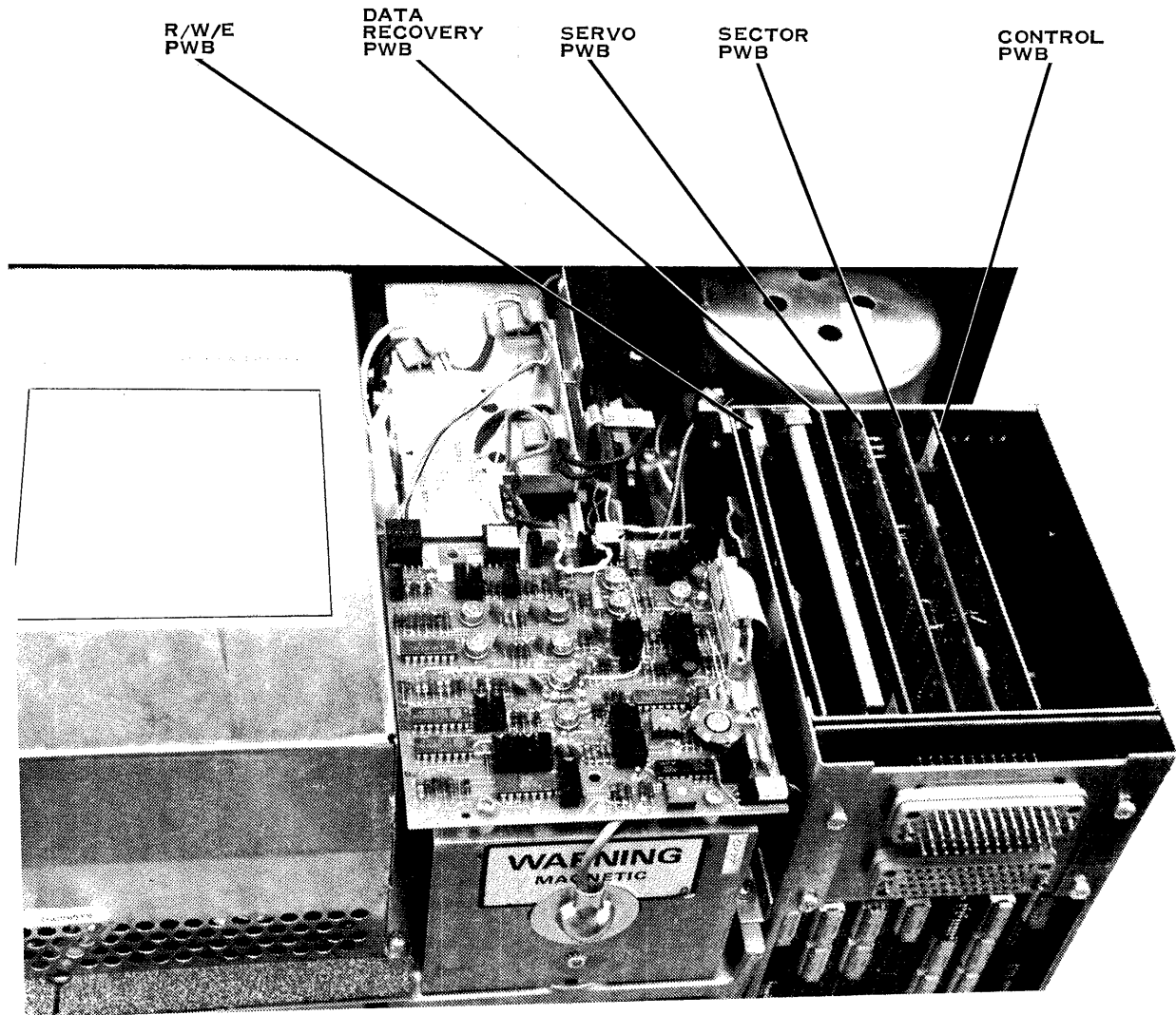

(A) 137239 (990-977-35-11)

Figure 2-10. Disk Drive PWB Locations

1. Use a utility knife to slit tape holding down top flaps of accessory package.
2. Remove disk controller package.
3. Remove tape holding two pieces of ethafoam together and carefully lift off the half that is on top. Either the circuit board or the ethafoam spacer is now exposed.
4. If circuit board is exposed (it is inside the ethafoam piece you have lifted), reassemble package and turn it over.



INDICATES SWITCH POSITION

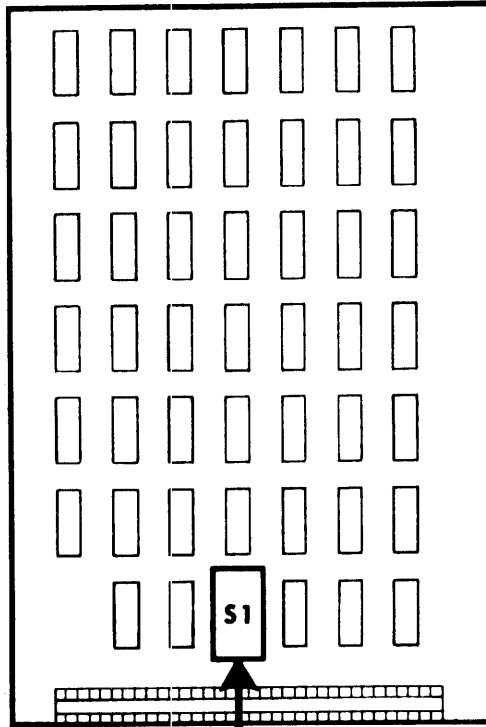

INVALID CYL. ADD. INTERRUPT
 DROP READY WITH FAULT
 (DENSITY STATUS) 100 TPI
 NO FIXED DISK
 ACTIVE LOW INTERRUPT
 ACTIVE HIGH INTERRUPT
 R.T.Z.S. RESETS FAULT
 SPARE

ON	S1	OFF
	8	<input checked="" type="checkbox"/>
<input checked="" type="checkbox"/>	7	
	6	<input checked="" type="checkbox"/>
	5	<input checked="" type="checkbox"/>
	4	<input checked="" type="checkbox"/>
<input checked="" type="checkbox"/>	3	
<input checked="" type="checkbox"/>	2	
	1	<input checked="" type="checkbox"/>

READY STAYS TRUE
 DURING FAULT CONDITION
 200 TPI
 FIXED DISK
 ACTIVE HIGH INTERRUPT
 ACTIVE LOW INTERRUPT
 R.T.Z.S. DOESN'T RESET FAULT
 SPARE

(A) 1372.40

Figure 2-11. Control PWB Switch Settings

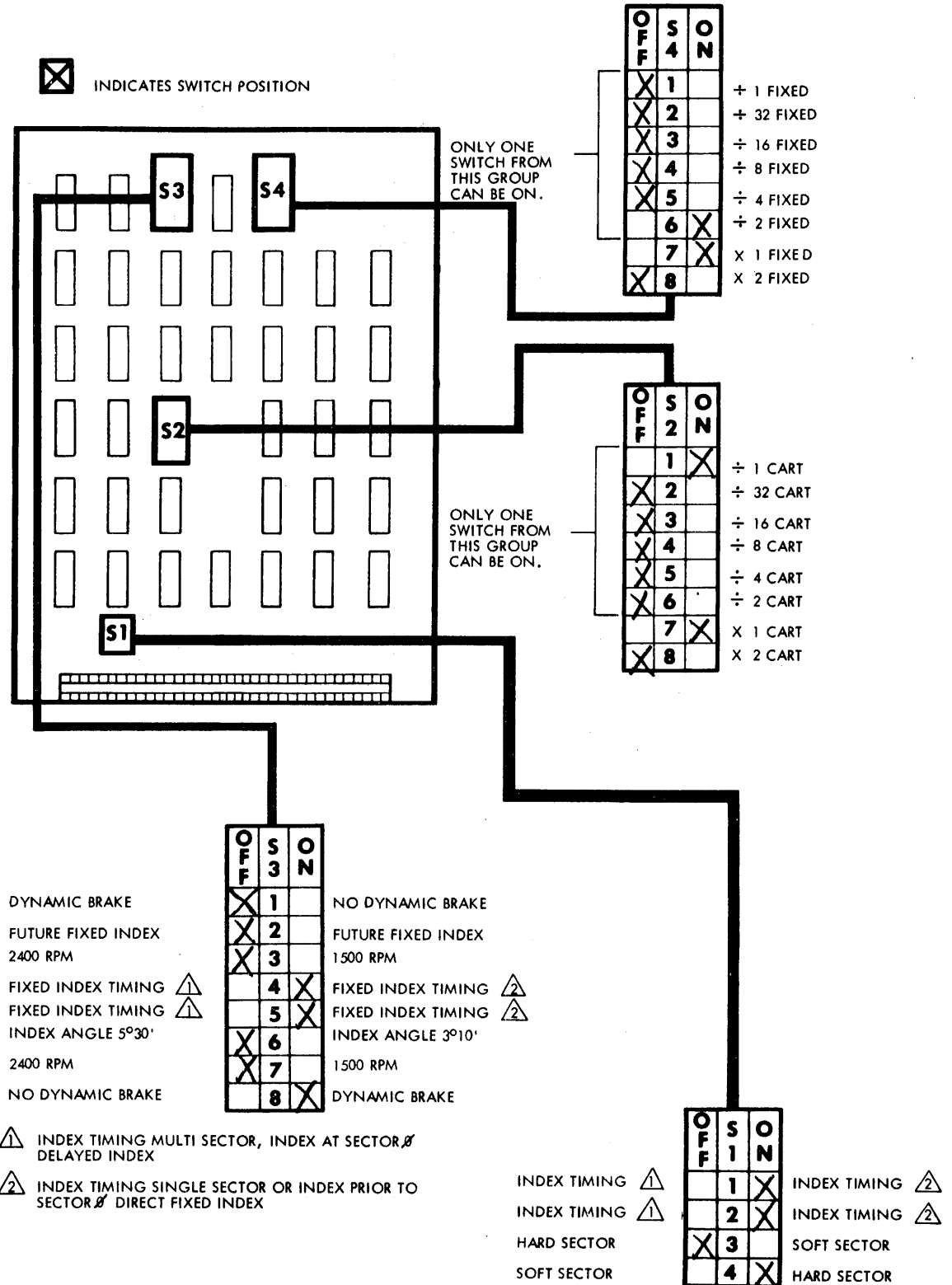

(A) 137241

Figure 2-12. Sector PWB Switch Settings

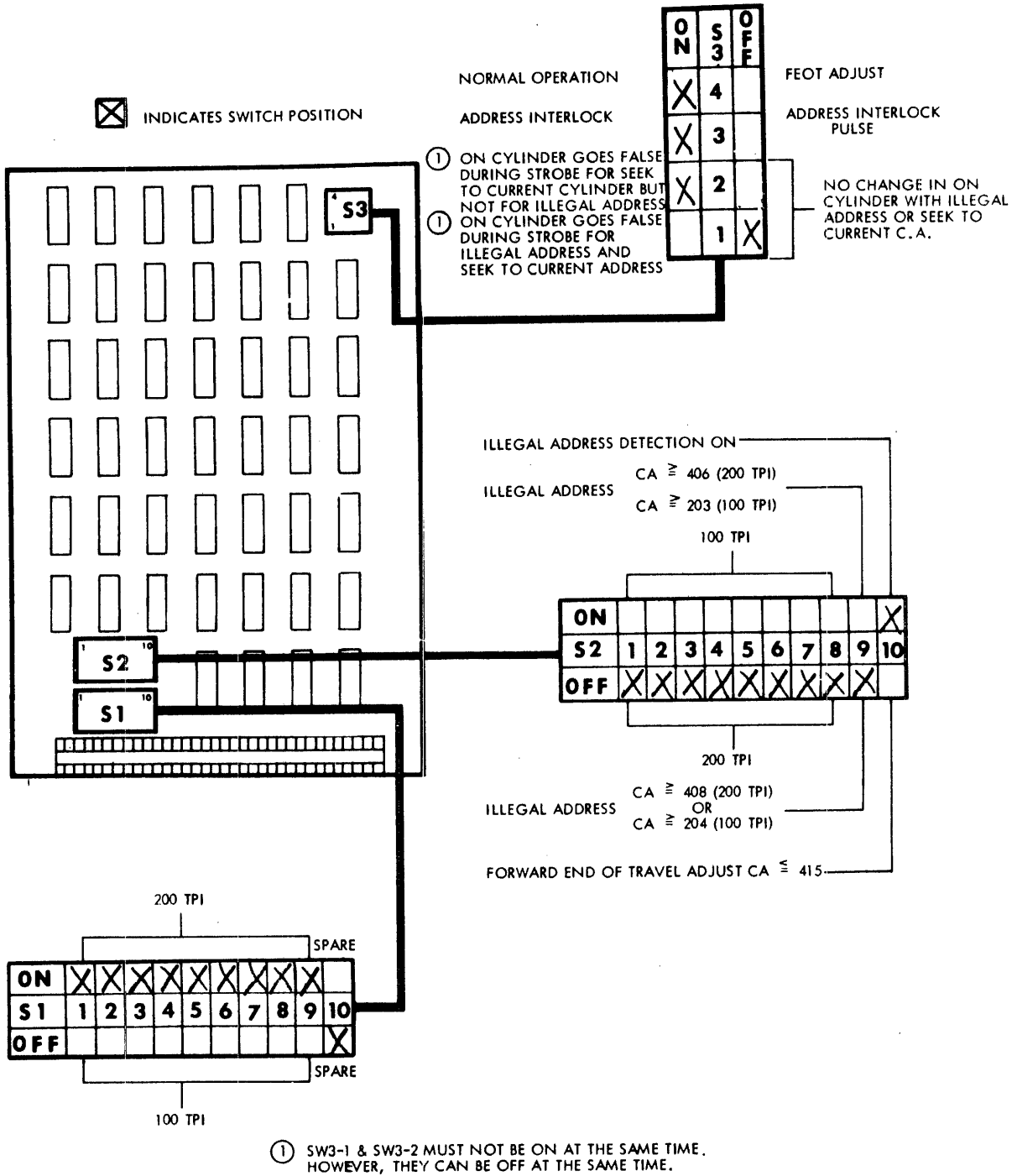

(A) 137242A

Figure 2-13. Servo PWB Switch Settings

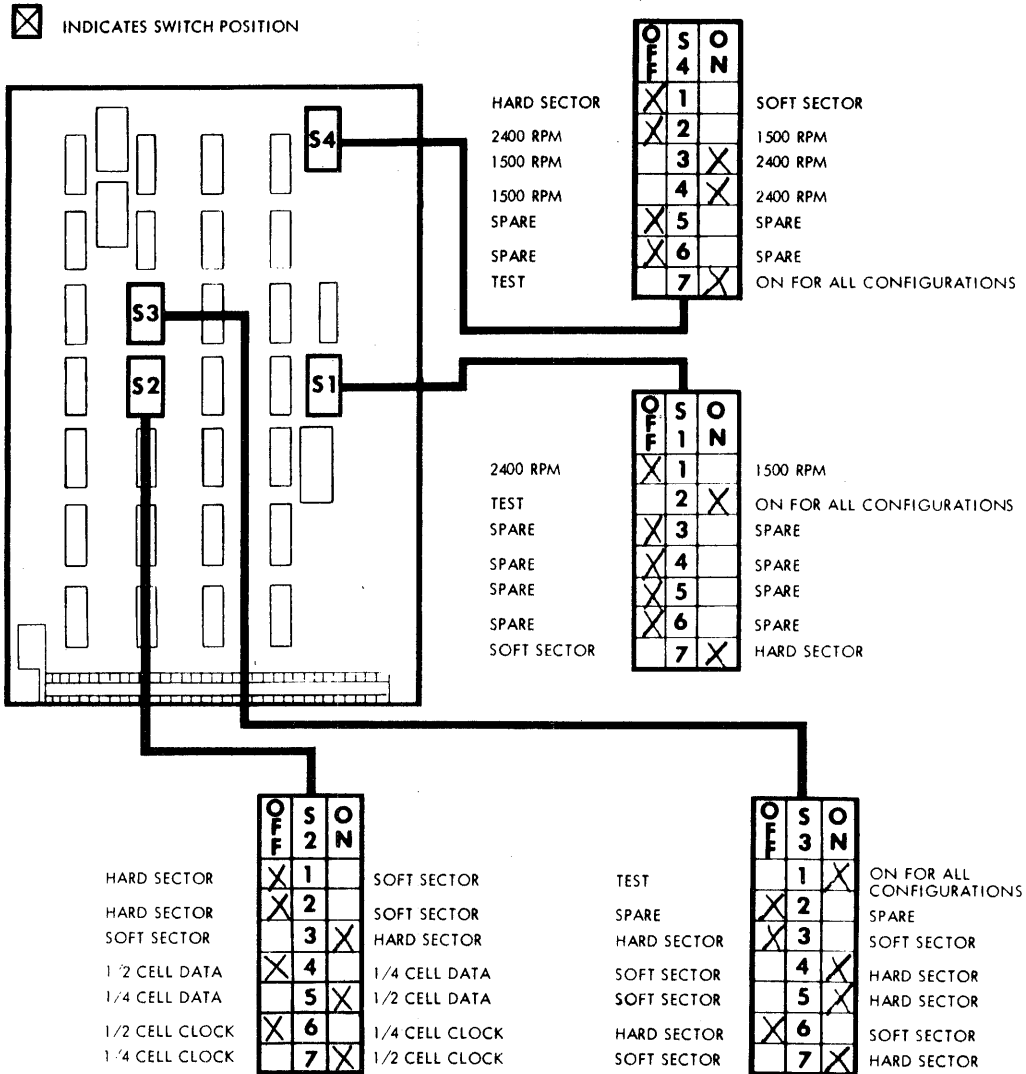

(A) 137268B

Figure 2-14. Data Recovery PWB Switch Settings

5. If ethafoam spacer is exposed, lift it off and set it aside. The circuit board is now exposed, taped along its edges to remaining half of the package.
6. Ensure jumpers (see Figure 2-17) are securely installed.
7. Remove tape and lift circuit board out of package.

2.3.3 UNPACKING CABINET MOUNT DISK DRIVE. Upon receipt of the container, inspect it to ensure that no physical damage occurred during shipment. If damage is apparent, notify carrier immediately.



● INDICATES LOCATION OF PIN 1

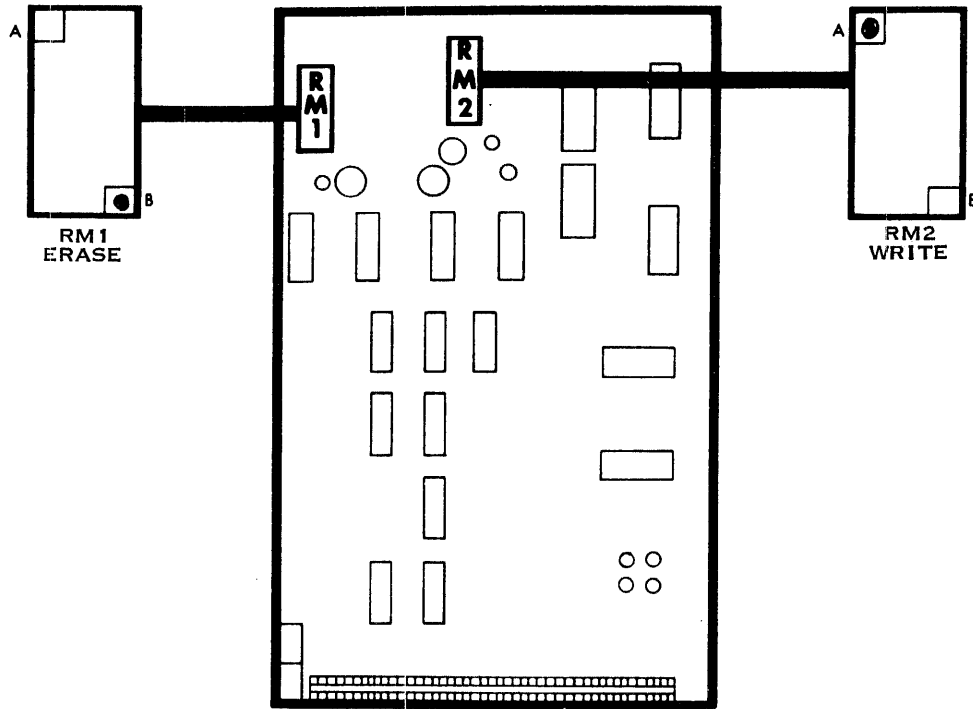

*	DESCRIPTION		RM1-(ERASE)		RM2-(WRITE)	
	TPI	ERASE TYPE	MOD. TYPE	PIN 1	MOD. TYPE	PIN 1
	100	PRE-ERASE	75300100	B	75300100	A
	100	STRADDLE ERASE	NONE		75300100	A
	200	PRE-ERASE	75300100	A	NONE	
X	200	STRADDLE ERASE	75300200	B	75300200	A

* RESISTOR MODULE USED INDICATED BY (X).

(A) 137269A

Figure 2-15. R/W/E PWB Resistor Module Orientation

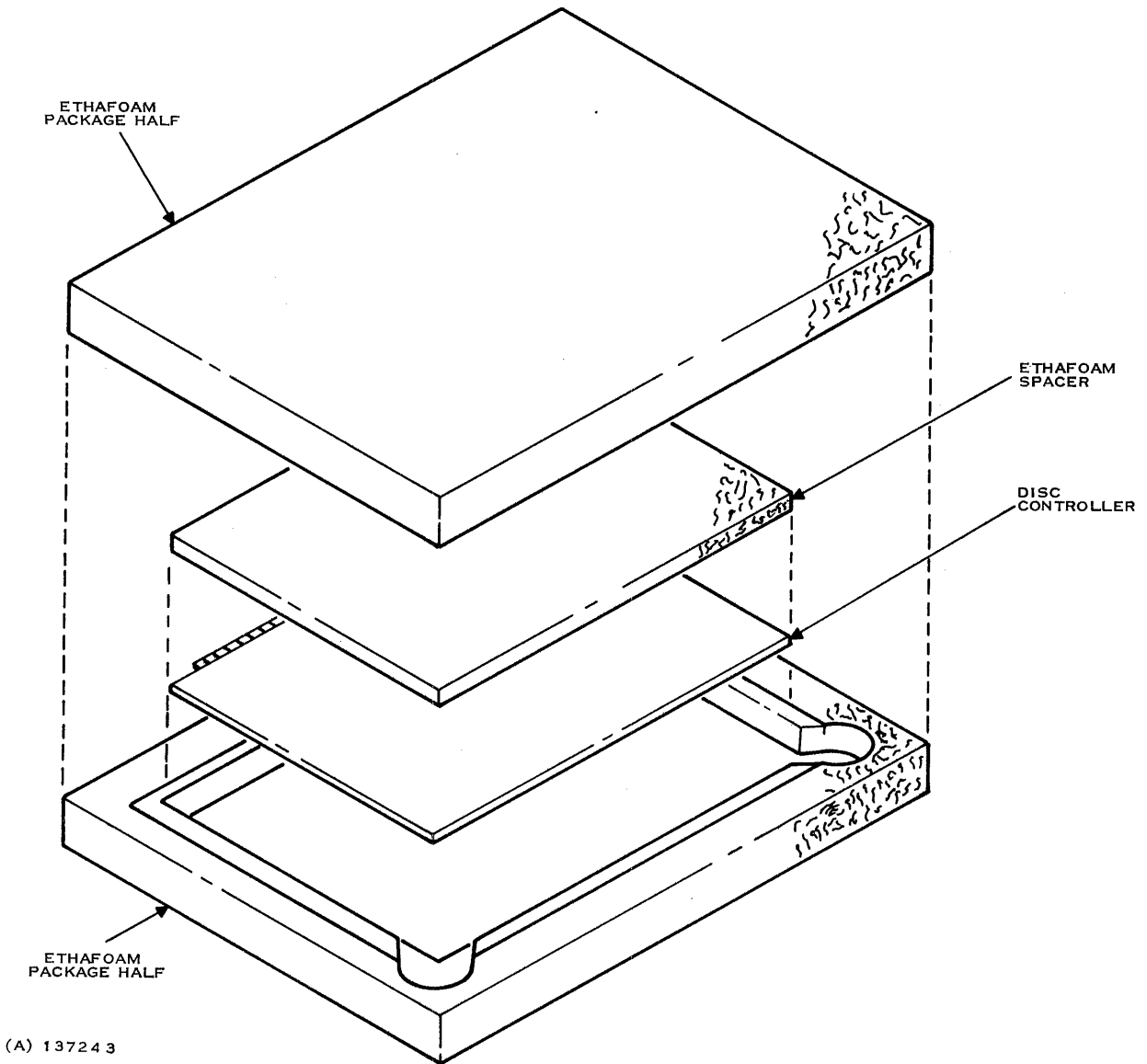

Figure 2-16. Disk Controller Shipping Configuration

WARNING

The unpacked cabinet mount disk drive weighs approximately 114 kilograms (252 pounds). When unpacked, handling of the unit requires at least two persons, and is simplified by use of a portable hoist or hydraulic lift for transporting the drive over long distances. The unit can be rolled on its casters over short distances.

NOTE

Save all shipping materials except where noted for use in reshipment of the unit.

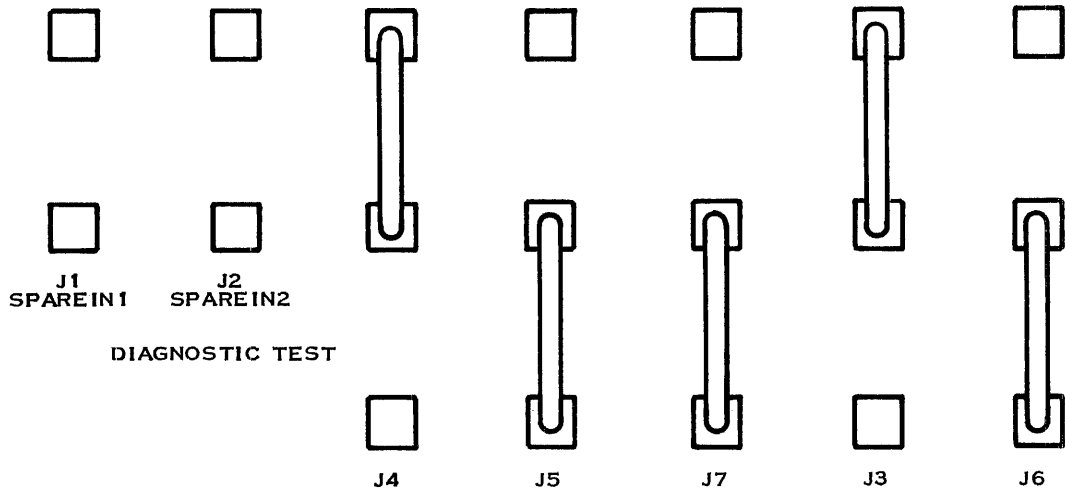

NOTE:

THE LONG SELF-TEST JUMPER MAY BE INSTALLED BETWEEN THE SPAREIN2 LINE (J2) AND GROUND FOR TEST PURPOSES ONLY. IT MUST BE REMOVED TO RESUME NORMAL OPERATIONS.

PWB VERSION

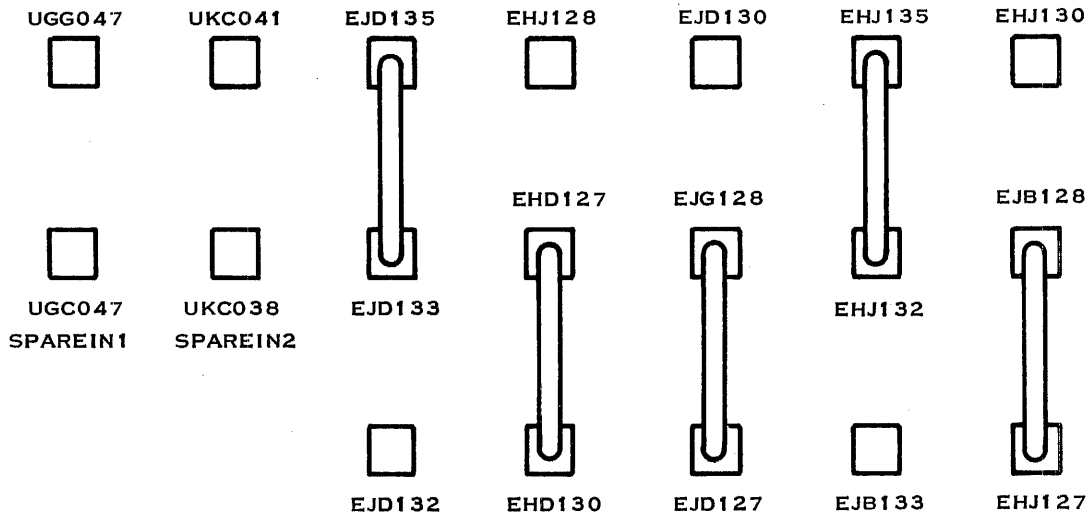

FINE LINE PWB VERSION

(A)143534A

Figure 2-17. Disk Controller Standard Jumpers



After ensuring that no damage has been done to the container or its contents during shipping, unpack the disk drive according to the following instructions:

1. Position container so that address label is upright.
2. Cut and discard metal bands around shipping container.
3. Open top flaps of shipping container and lift out wood and ethafoam spacer.
4. Lift shipping container by flaps up and off assembly.
5. Use a claw hammer or wrecking bar to dismantle sides of inner packing assembly.

WARNING

Do not attempt to lift disk drive alone or by top assembly.

6. Using a hoist, portable lift, or another person, lift the disk drive up and off the base and set it on floor.
7. Lift the front of the rear cover of the disk drive and rotate it backward to expose the electronics cover.
8. Remove three screws (Figure 2-7) that hold electronics cover in position and remove electronics cover.
9. Remove carriage lock pin (Figure 2-8) by rotating head of pin 90 degrees counterclockwise and pulling straight up. Store pin on side of magnet as shown in Figure 2-8.
10. Reinstall electronics cover and reposition rear disk drive cover.

2.3.4 UNPACKING ACCESSORIES. The interconnection cables, whether for a primary or secondary disk drive, slides (for rack mount only), and all manuals and paperwork shipped with the disk drive are shipped wrapped in plastic bags in the accessory package. Open the bags and remove the accessories.

2.3.5 UNPACKING, HANDLING, AND STORING DISK CARTRIDGES. The disk cartridges are shipped in reusable corrugated shipping containers that are lined with polyurethane foam. The entire container, including the disk cartridge, can be handled by one person. The shipping container provides adequate storage protection for the disk cartridge with no degradation of performance when stored in specified environments as described in following paragraphs.

CAUTION

When storing disk cartridges in the shipping containers, do not stack the containers more than eight high.



2.3.5.1 Unpacking Disk Cartridges.

CAUTION

Disk cartridges are precision instruments. Tolerances as small as a few millionths of an inch are common. A little precaution in the handling and storing of disk cartridges can prevent costly rerun time and protect valuable data recorded on the disks.

Open the shipping carton and unpack the disk cartridge as follows:

1. Inspect shipping container for any evidence of damage.
2. Remove disk cartridge from shipping container and protective bag.
3. Remove cartridge from bottom cover and turn upside down on top cover. Perform visual inspection of bottom protective disk. Look for dents or scratches.
4. Carefully clean inside of disk cartridge top and bottom covers with a clean, lint-free cloth moistened with water or isopropyl alcohol. Be careful to prevent any foreign material from entering the disk area.
5. Always keep top and bottom covers of canister together when the cartridge is not in use. Dust and lint can accumulate in an open canister and may later contaminate the cartridge.

CAUTION

Do not, under any circumstances, attempt to use a disk cartridge that you suspect is damaged because such usage can cause damage to the disk drive.

CAUTION

The disk cartridge used with the Model DS10 Cartridge Disk Drive must be in accordance with Texas Instruments Specification 937507. The recording surfaces in the disk cartridge must be error-free.

The case, or canister, of a disk cartridge consists of a plastic top cover with a handle and a bottom cover (see Figure 2-18). The handle locks with the cartridge spindle, and the disk cartridge should be carried from place to place by the handle. The disk cartridges should be stored in the same room environment as the disk drive or brought into the room for temperature conditioning no less than one hour prior to use.

2.3.5.2 Handling Disk Cartridges. The following precautions should be observed when handling disk cartridges.

CAUTION

To prevent dust, dirt, and foreign material from entering a disk cartridge and contaminating the disk, the disk cartridge should always be in its cover when not in use.

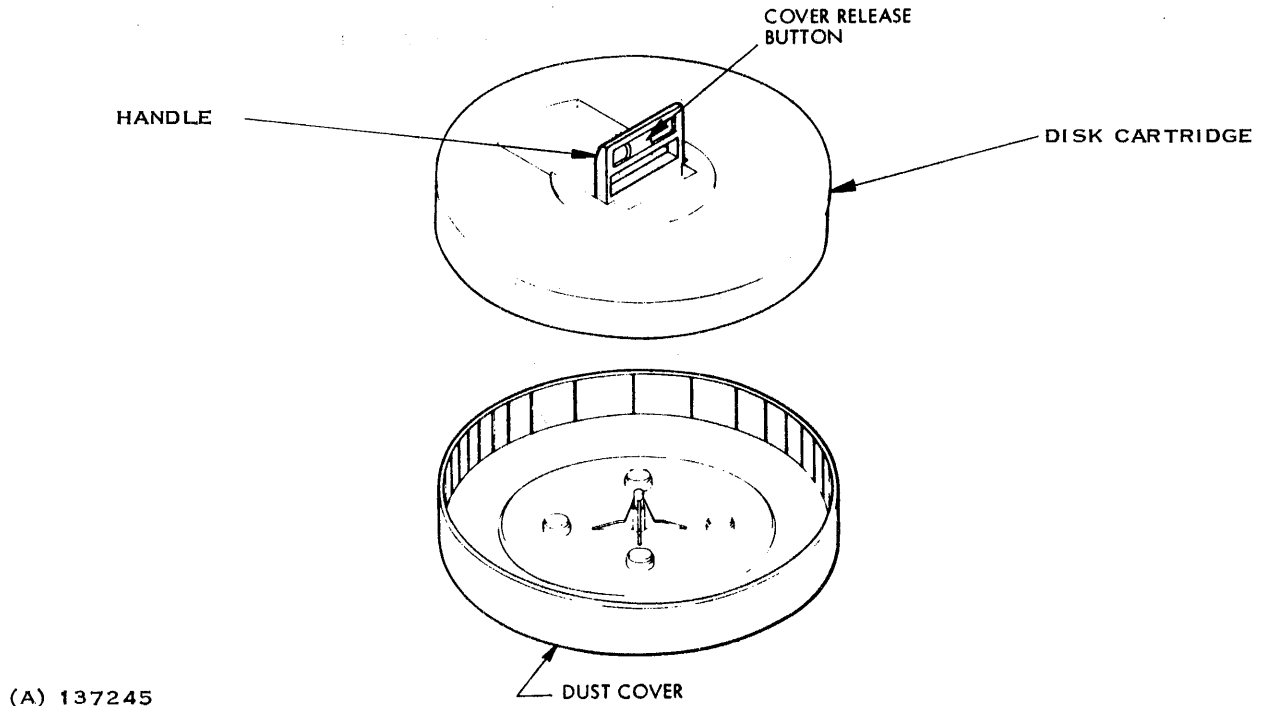

Figure 2-18. Disk Cartridge

1. Carry disk packs from place to place using the handle.
2. Always reassemble the disk cartridge by setting the dust cover down on a solid surface, then placing the cartridge into the dust cover.
3. Never set the disk cartridge on any surface without the dust cover in place.
4. Never stack disk cartridges or set anything on top of a disk cartridge.

2.3.5.3 Storing Disk Cartridges. The following precautions should be observed when storing disk cartridges.

1. Always store the disk cartridges in the operating environment listed in Table 2-2.
2. Disk cartridges that have been stored in, or subjected to, environments outside the range listed in Table 2-2 should be conditioned to the environment listed in Table 2-2 for at least 24 hours prior to use. During this period of conditioning, the cartridges should be removed from their containers.
3. For long term storage, store the disk cartridges in their original shipping containers no more than eight high. The containers provide protection against dust and debris, large environmental changes, contamination by chemicals, and physical damage.



2.3.6 VOLTAGE CONVERSION PROCEDURES. If the disk drive is to be operated from any of the voltages listed in Table 1-3 other than 100 volts, 50 hertz, 110 volts, 60 hertz, or 230 volts, 50 hertz, the following procedure should be performed at this time to prepare the disk drive.

1. Remove voltage adapter assembly (Figure 2-19) at lower left of rear of the drive next to power cord.

NOTE

For each voltage option, there are two jumpers. One end of each jumper is fixed (pins 14 and 15) and should not be removed.

2. Refer to Table 2-3 for proper jumper connections for desired voltage.
3. Pull moveable end of jumper(s) out of plug and reinsert into location indicated by Table 2-3.
4. Install jumper plug into connector.
5. If necessary, remove existing line cord plug and replace with a new one (customer-supplied) to provide proper mating of line cord with power outlet.
6. Alter voltage designation on ID plate at rear of disk drive to reflect new operating voltage.

2.4 INSTALLATION

Installation of the disk system consists of attaching slides to the rack mount disk drive and installing the drive into a rack, or positioning a cabinet mount disk drive; attaching cables to the disk drive(s) and routing the cables to the computer chassis; preparing the computer chassis to receive the disk controller; preparing the disk controller slave address; and installing and cabling the disk controller.

2.4.1 INSTALLATION OF RACK MOUNT DISK DRIVE. Installation of the rack mount disk drive consists of attaching the rack slides to the disk drive and then installing the assembly into a properly positioned rack. The following procedure should be observed.

NOTE

Refer to Figure 2-20 during the following steps.

1. Attach a plastic slide mount and a plastic keyed slide mount to each side of the disk drive with 8-32 × 5/8-inch panhead machine screws and No. 8 internal-tooth lock washers.

NOTE

Orient V-groove channel in unkeyed plastic mount downward.
Orient flat sides of keyed mounts inward and downward.

2. Attach a plastic stabilizer to each side of disk drive with 8-32 × 1/2-inch panhead machine screws, No. 8 internal-tooth lock washers, and No. 8 flat washers.

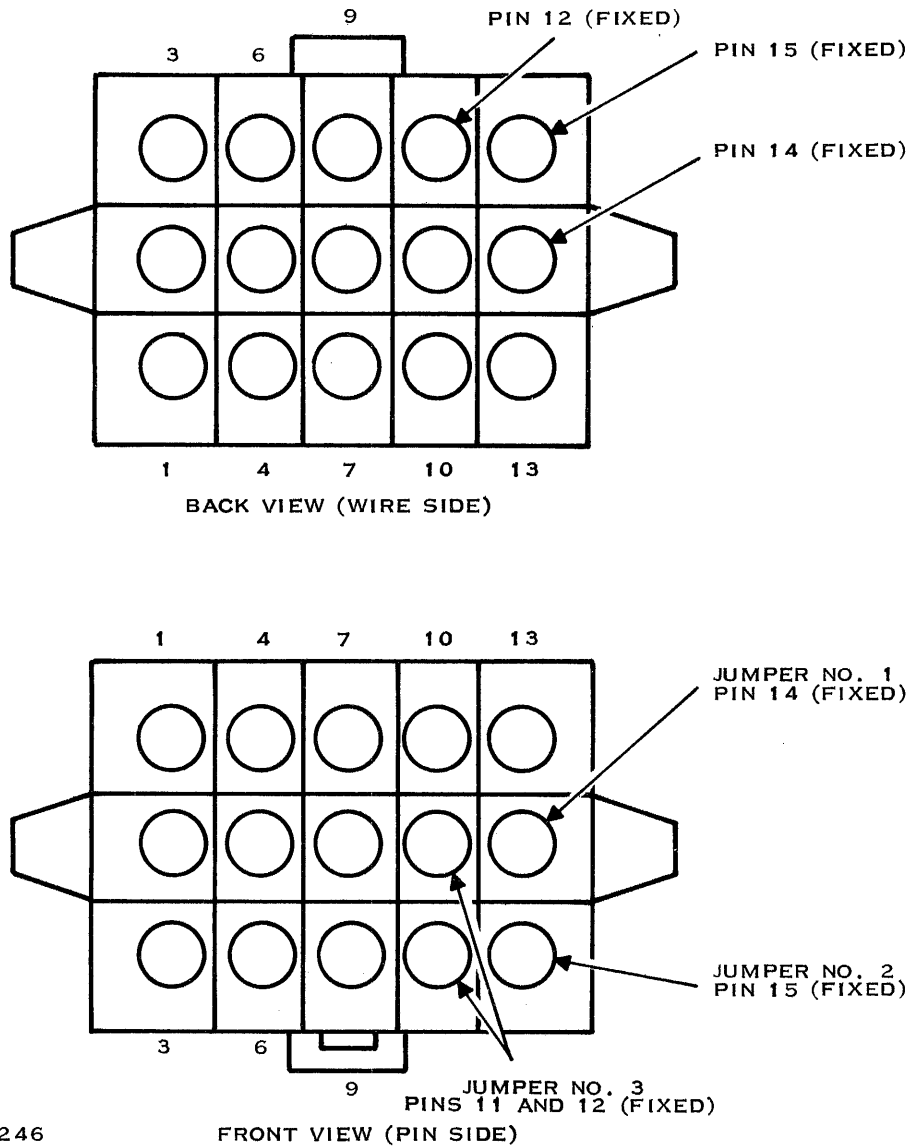

(A) 137246

Figure 2-19. Voltage Jumper Plug and Connector

NOTE

The stabilizers should be mounted with their keys extending downward. Leave stabilizers slightly loose at this time.

3. Adjust the slides so that the dimensions of the assembly correspond to those shown in Figure 2-2.
4. Adjust and secure the front mounting brackets so that the flange fronts are flush with fronts of slides (See Figures 2-20 and 2-21).



Table 2-3. Disk Drive Input Voltage Jumper Connections

Voltage	Jumper No. 1		Jumper No. 2	
	Fixed Pin	Moveable Pin	Fixed Pin	Moveable Pin
100	14	4	15	7
110	14	3	15	7
120	14	2	15	7
130	14	1	15	7
140	14	6	15	8
150	14	5	15	8
160	14	4	15	8
170	14	3	15	8
180	14	2	15	8
190	14	1	15	8
200	14	6	15	9
210	14	5	15	9
220	14	4	15	9
230	14	3	15	9
240	14	2	15	9
250	14	1	15	9

NOTE

The flanges can be located as much as 25 millimeters (one inch) in front of the slide ends to accommodate certain rack dimensions. Maximum extension of the unit out of the rack is reduced by this action.

5. Adjust and secure rear mounting brackets and cable retractor (left side only) as shown in Figures 2-20 and 2-21.
6. Ensure that the white plastic button in each front slide mounting bracket is in one of the two holes provided so that the button is on top and can act as a bearing between the moving and nonmoving parts of the slides.
7. Extend slides to full extension. The intermediate catches at 457 millimeters (18 inches) must be released on both sides. Slides lock at full extension.
8. With the aid of an assistant or a lift, set the disk drive on top of the slides, ensuring that all four plastic slide mounts rest on the top edges of the slides and that keys of front mounts engage notches in slides.

CAUTION

Use only 8-32 × 5/16 screws for mounting slide to plastic-keyed slide mount. If longer screws are used, the ribbon cable on the left side will be damaged.

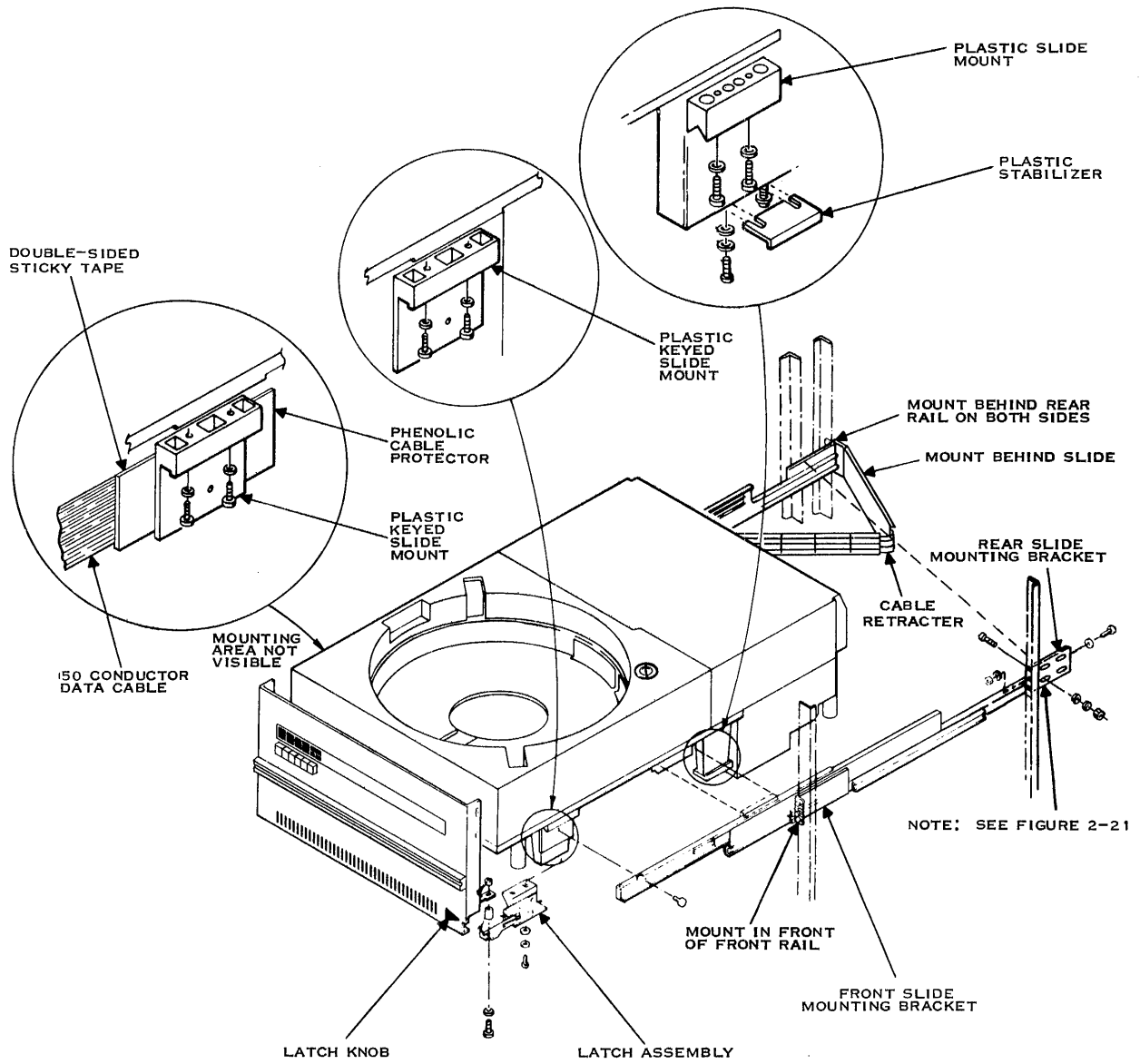

NOTE: THE TAPPED ANGLE ASSEMBLIES (973712-0006 FOR 1778 MM (70 IN.) RACK, 946738-0010 FOR 762 MM (30 IN. RACK) AND THE CABLE CARRIER 996745-0001 ARE SUPPLIED WHEN DISK IS PURCHASED AS PART OF A DS990 KIT.

(A) 137248A

Figure 2-20. Rack Slide Assembly Mounting

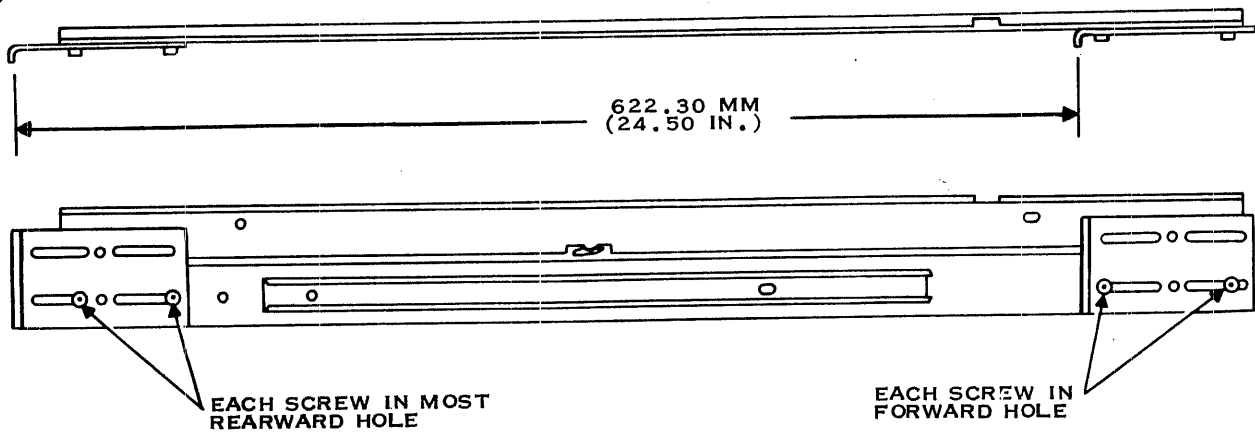

(A) 137698A

Figure 2-21. Rack Mount Slide Configuration (Right Side Only)

9. Coat threads of two 8-32 \times 5/16-inch panhead screws with Grade C Loctite (or equivalent) and install through each slide into keyed slide mounts.
10. Adjust stabilizers installed in step 2 to prevent wobbling and to provide smooth slide operation. Tighten stabilizers.
11. Attach latch assembly to disk drive with 8-32 \times 5/8-inch panhead machine screws. No. 8 lock washers and No. 8 flat washers. Leave screws slightly loose at this time.
12. Insert knob through front panel and attach to latch assembly with an 8-32 \times 5/8-inch panhead machine screw, a No. 8 internal-tooth lock washer, an 8-32 \times 1/4-inch spacer, and an 8-32 hex machine nut.
13. Adjust latch so it catches front vertical rack rail, securely holds disk drive in retracted position, and releases easily when knob is pushed to left.

2.4.2 INSTALLATION OF CABINET MOUNT DISK DRIVE. Installation of the cabinet mount disk drive consists of placing the unit in the space provided for it and leveling the unit. Leveling should be performed after the interconnection cables have been connected to the disk drive. Level the cabinet as follows:

1. Remove jack screws from plastic container.
2. Lift one side of cabinet and support it high enough to insert jack screws.
3. Start jack screws into threaded holes beside casters. Thread screws into holes far enough to allow casters to touch floor when unit is lowered.
4. Lower cabinet and repeat steps 2 and 3 for opposite side.
5. Unscrew jack screws until casters are raised off floor.



6. Using a level as reference, adjust jack screws until cabinet is level along all four sides of cabinet top.

2.4.3 COMPUTER CHASSIS PREPARATION FOR DISK CONTROLLER. If the disk drive system is shipped as part of the Model 990 Computer system, the computer chassis is shipped with chassis slots assigned, interrupt connections properly made, etc. Normally, the disk controller is installed in computer chassis slot 7 (in a 13-slot chassis), its TILINE address is set to >FFC00 (the symbol >indicates hexadecimal), its interrupt level is set at 13, and the access granted connections are permanently made. No further preparation is necessary for a computer chassis shipped with a disk controller installed. If the disk system is shipped separately from the initial computer system, or if the configuration is to be changed, the computer chassis must be adapted for the new configuration. If a nonstandard configuration is used, refer to the computer hardware reference manual for the proper model (990/5, 990/10, or 990/12). (See the preface for the formal titles and part numbers of these manuals.) In addition, the power capacity of the computer chassis must meet the requirements of the disk controller and all other boards installed in the chassis. The disk controller requires +5 Vdc at 5.5 amperes and -12 Vdc at 0.03 ampere.

If a computer chassis slot other than slot 7 is selected, the TILINE access granted signal chain must be modified. This is accomplished by removing the jumper in the access granted circuit, as described in paragraphs 2.4.3.1 and 2.4.3.2.

If the controller is not purchased as part of the system, the user may have to make the interrupt connections as part of the board installation. Paragraphs 2.4.3.3 and 2.4.3.4 describe the interrupt connections.

TILINE address settings and Interrupt assignments must be coordinated with the operating system software. If you are adding on to a previously-purchased system, refer to the system generation instructions in the operating system documentation upon completion of the hardware installation.

2.4.3.1 Reconfiguring Access Granted Circuit for New Chassis Slot (6- and 13-Slot Chassis). The TILINE is a common data path that is connected to all slot positions in the 990 chassis. Users of this bus fall into two major types: masters and slaves. Slave devices are addressed by master devices and commanded to accept or transmit data. Some TILINE peripherals, including the disk drive controller, have both master logic and slave logic.

In order to resolve conflicts between multiple masters contending for TILINE control, a positional priority scheme is used. The TILINE access-granted signal, which established positional priority among masters, is wired along the P2 side of the chassis. The TILINE master installed in the highest numbered slot has the highest priority, with priority decreasing with each slot toward the central processor location (or slot 1).

The TILINE access granted signal enters each master on backplane connector P2, pin 6. The signal leaves the master on pin 5 of P2. Logic circuitry on the master controller allows the access granted output to be inhibited to lower priority masters.

For chassis slots not occupied by TILINE masters, jumpers or etch on the backplane connector pins are installed to ensure continuity. By convention, the jumpers are installed at all available slot locations except slot 7. Slot 7 is reserved for the first TILINE master device (positional priority); in this case, the disk controller. Additional TILINE masters may be inserted at slot positions of higher or lower priority if the jumper connected between P2-5 and P2-6 is removed at the selected slot locations.



Installing a disk controller in a location other than slot 7 requires that the TILINE access granted jumper (P2-5 to P2-6) be removed from the chosen slot, and that the continuity of the TILINE access granted lines between the highest priority master and the central processor board must be preserved. This means that if an intermediate slot is assigned to a TILINE master, that master must be installed to preserve continuity and to allow the priority system to function.

Current production assemblies have the TILINE access granted jumpers accessible from the connector side of the motherboard when all boards are removed from the chassis. These jumpers are shown in Figures 2-22 and 2-23. Simply remove the jumper plug (or cut the jumper, if the jumper is a wire) for the selected chassis slot, and reinstall all circuit boards in their proper location. As noted previously, the continuity of the TILINE access granted line from the highest TILINE master to the central processor must be preserved. Therefore:

1. All slots other than those containing TILINE master controllers must have the TILINE access jumper installed.
2. All master controllers must be installed in their proper location.

If the chassis is an early production version (i.e., if it does not have jumpers as shown in Figures 2-22 or 2-23), it is necessary to remove the back cover and power supply to gain access to the TILINE access granted jumpers. For these chassis, the following steps should be followed:

1. Turn off all power and unplug the computer ac line cord.

WARNING

Lethal voltages are exposed when the access cover is removed. Power supply capacitors may retain charges long after ac power is removed.

2. Remove the left access cover (as viewed from the front of the chassis). The cover is fastened by four or six hex head machine screws.
3. If the chassis is a 13-slot chassis with a 20-ampere power supply, slots 1 through 6 are visible above the power supply. To work on these slots, proceed to step 4. To work on any other slots, remove the power supply as follows:
 - a. Disconnect the color-coded connectors from the component side of the power supply board.
 - b. Unscrew the machine screws and standoffs that secure the power supply to the frame and to the motherboard.
 - c. Carefully pull the power supply board straight forward until the connector at the bottom center of the power supply board is disengaged from the pins protruding from the motherboard. Lift the power supply board out of the chassis.



ASSY. 945010-0001 REV ()

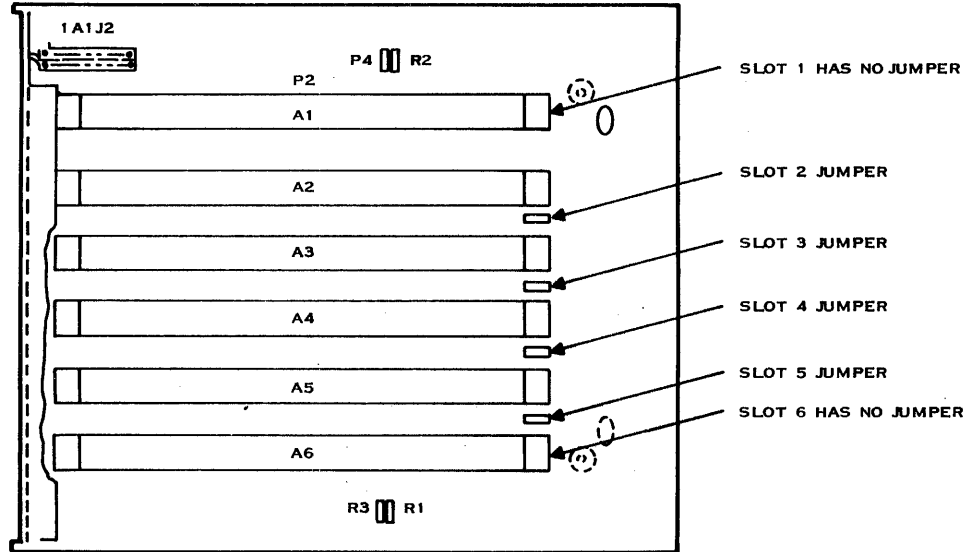

NOTE: JUMPERS ARE REMOVABLE JUMPER PLUGS.

(A) 138671

Figure 2-22. TILINE Access Granted Jumper Locations for 6-Slot Chassis (Current Production)

4. The rear of the motherboard is now exposed. The P2 connectors are at the left side, nearest the fan. Refer to Figure 2-24 for views of the left end of the P2 connector in a 13-slot and 6-slot chassis.
5. In a 13-slot chassis, the TILINE access granted jumpers (P2-5 to P2-6) are wire jumpers soldered to the connector pins as shown in view A of Figure 2-24. To remove a jumper, clip the jumper at each end as close as possible to the pins and remove the wire.
6. In a 6-slot chassis, the jumpers are part of the printed wiring board etch as shown in view B of Figure 2-24. Note that pins 1 and 2 are concealed by the ground plane. To remove a jumper, cut the jumper etch at two points with an X-acto* knife and lift off or scrape away the excess conductor.



ASSY. 945015-0001 REV (R)

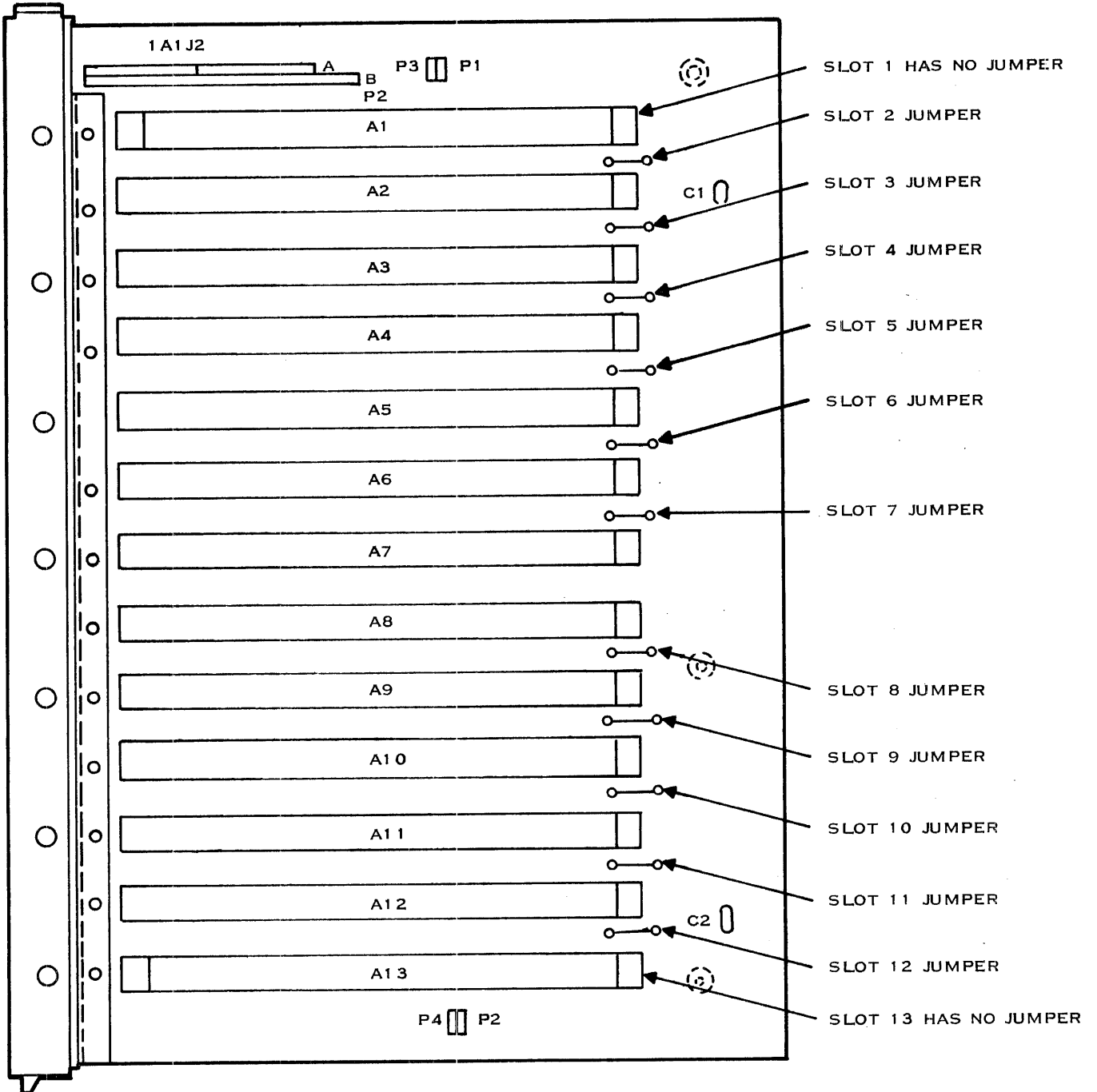

NOTE: JUMPER MAY BE EITHER A REMOVABLE JUMPER PLUG OR A WIRE WHICH MUST BE CUT.

(A) 138672

Figure 2-23. TILINE Access Granted Jumper Locations for 13-Slot Chassis (Current Production)



7. To install a jumper, solder a short length of #26 AWG wire between P2-5 and P2-6.
8. To reinstall the power supply, proceed as follows:

CAUTION

The male pins protruding from the lower center of the motherboard are subject to bending if the mating connector on the power supply is not properly aligned with these pins.

- a. Slip the power supply over the cable harness and into the side of the chassis. The metal-shell jumper connector (for the standby power supply) should appear at the bottom center of the power supply board.
- b. Align the power supply circuit boards on the two alignment pins and *carefully* slide the board straight back so that the pins protruding from the motherboard slip into the connector on the power supply circuit board. The view of these pins is blocked by the power supply board.
- c. Reinstall the machine screws and standoffs that hold the power supply in place. Do not omit the lockwashers, as both mechanical and electrical connections are made by the machine screws and standoffs.
- d. Reconnect the power supply to the wiring harness by installing the color-coded plastic connectors.

*X-acto is a registered trademark of X-acto Corporation

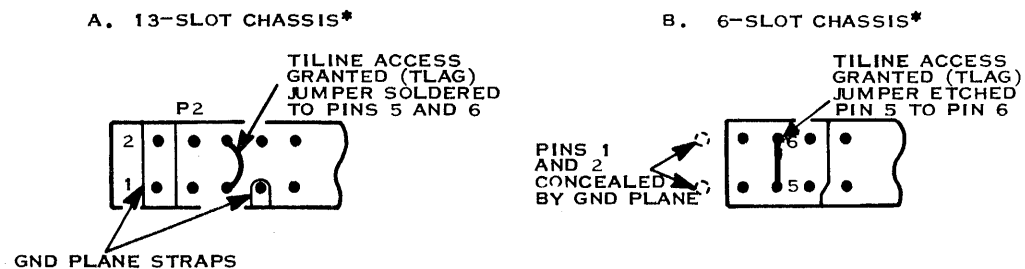

*NOTE THESE ARE REAR VIEWS OF THE 990 MOTHERBOARD, I.E., VIEWS FROM THE POWER SUPPLY SIDE.

(A) 133946A

Figure 2-24. TILINE Access Granted Jumpers (P2-5 to P2-6) on the Model 990 Backpanel



9. Reinstall the cover removed in step 2.
10. Record the new slot assignment on the configuration chart affixed to the chassis.

2.4.3.2 Reconfiguring Access Granted Circuit for New Chassis Slot (17-Slot Chassis). Continuity of the TLAG jumpers in the 17-slot chassis is controlled by two socket-mounted DIP switches, each with eight individual switch sections. These switches are accessible from the rear of the 17-slot chassis, as shown in Figure 2-25. To set or check these switches, the following steps should be performed.

1. Turn off power and unplug the chassis ac line cord. Allow about 30 seconds for the power supply bleeders to discharge the power supply capacitors.

WARNING

Opening the chassis rear cover (power panel) exposes high voltages if the ac line cord is installed in a live socket. Do not contact the large filter capacitors on the power module.

CAUTION

The wire hinges on the chassis rear cover do not allow the cover to pivot beyond 90 degrees. Attempts to open the chassis rear cover beyond 90 degrees may damage the hinge mountings.

2. Using a coin or flat-bladed screwdriver, release each of the 11 quarter-turn latches on the chassis rear cover. Pull the cover straight back 38 millimeters (1.5 inches) to extend the wire hinges, and then open the cover to the 90-degree position. The hinges are on the right as viewed from the rear of the chassis.
3. Refer to Figure 2-26, which shows the correspondence between switch sections and chassis slots. Set the appropriate switch segment OFF for any slot which is assigned to a TILINE master device, such as the disk controller. All other switch segments should be ON.
4. Refer to paragraph 2.4.3.4 if interrupt assignments are to be changed.

CAUTION

There is a possibility of interference between heat sinks in the chassis and modules mounted inside the rear access cover as the door is closed. Do not force the door closed if resistance is felt.

5. Rotate the door to a position parallel to the rear of the chassis, with hinges fully extended. Grasp the rear access cover at the left and right sides and push it straight back to its mounting position against the chassis.
6. Using a coin or screwdriver, lock the 11 quarter-turn latches which hold the access cover in position.
7. Record the new slot assignment on the configuration chart affixed to the chassis.

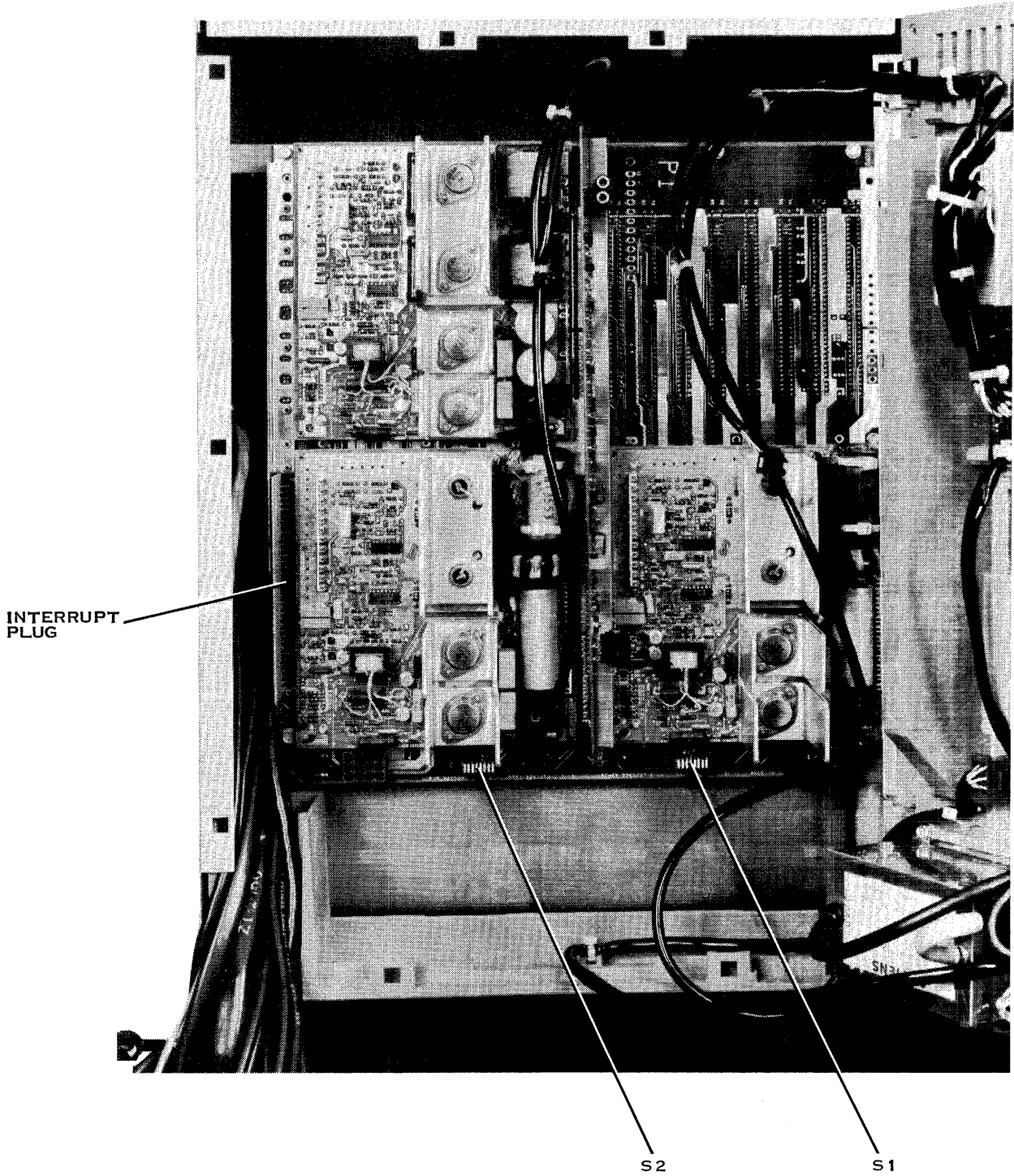

(A)141779

Figure 2-25. Interrupt Plug and TLAG Jumper Switches in the 17-Slot Chassis



946261-9701

ON = TLAG JUMPERED ACROSS SLOT (P2-6 TO P2-5)
OFF = TLAG NOT JUMPERED - CONTINUITY REQUIRES TILINE CONTROLLER

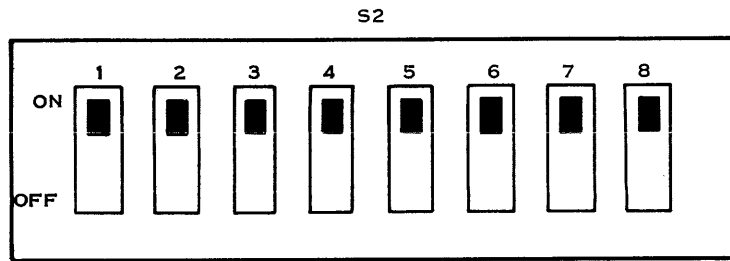

CHASSIS
SLOT: 2 3 4 5 6 7 8 9

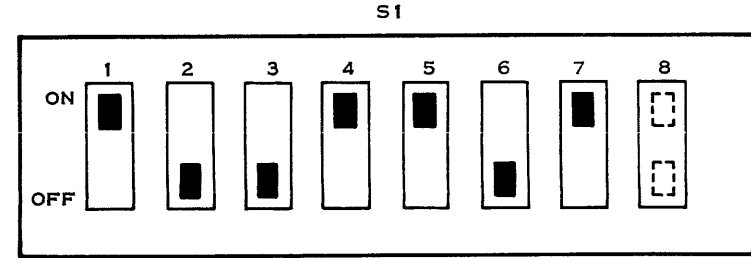

CHASSIS
SLOT: 10 11 12 13 14 15 16 N/C

- NOTES: 1. SWITCHES ARE SHOWN SET FOR:
- | | |
|--|-----------|
| SYSTEM DISK CONTROLLER | - SLOT 11 |
| 979A TILINE MAGNETIC TAPE CONTROLLER | - SLOT 12 |
| FD1000 TILINE FLEXIBLE DISK CONTROLLER | - SLOT 15 |
2. EACH SWITCH SECTION MUST BE ON UNLESS A TILINE MASTER CONTROLLER IS INSTALLED IN THE CORRESPONDING CHASSIS SLOT. TILINE PRIORITY SYSTEM WILL NOT WORK IF SWITCHES ARE SET INCORRECTLY.
3. SLOT 17 DOES NOT REQUIRE A SWITCH.

(A)141767A

Figure 2-26. 17-Slot Chassis TLAG Jumper Switch Settings



2.4.3.3 Interrupt Connections (for 6- and 13-Slot Chassis). Interrupt connections required to interface peripheral equipment to the 990 processor are usually made before the system is delivered to the customer. These interrupt assignments are coordinated with the software supplied with the system. However, if the controller is not purchased as part of the system, the user may have to make the interrupt connections as part of the board installation. Standard Texas Instruments software expects to find the controller interrupt assigned to interrupt level 9, which is connected to slot 8 in the standard chassis configuration. If the controller is installed in slot 9 or 11, the interrupt jumpers will have to be changed, or a different interrupt level assigned to the software.

The 990 processor has 16 interrupt levels, numbered 0 through 15. Interrupt level 0, which is internal to the processor, has the highest priority. Interrupt levels 3, 4, and 6 through 15 are external inputs which are available for assignment to peripheral controllers installed in the chassis. Interrupt level assignments must be coordinated with the software, so that the processor may correctly respond to (and clear) the interrupts.

Chassis backplane wiring brings the interrupt output lines from slots 2 through 3 and the processor interrupt lines to wire-wrap pin headers adjacent to slot 1. Jumper wires between the pins connect the circuit board interrupt outputs to the processor interrupt inputs. These jumpers may run directly from pin to pin, or may be mounted on jumper plugs which slip over the pins. Figure 2-27 shows the jumper plugs installed in the chassis. The jumper wires are omitted for clarity.

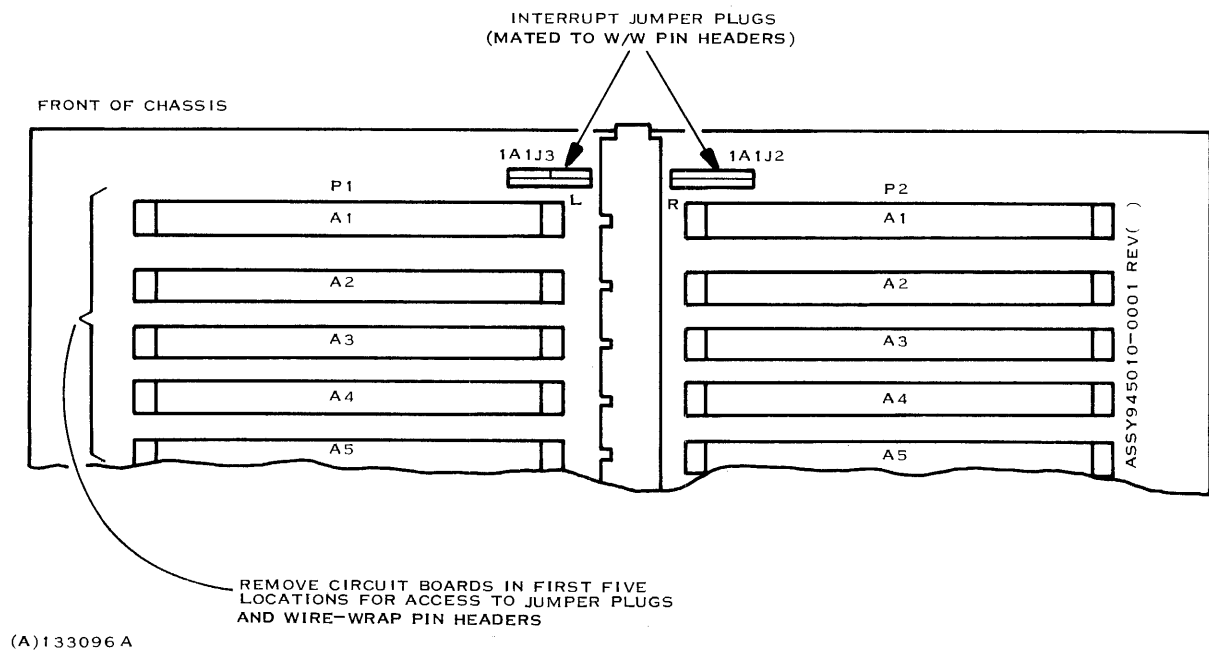

Figure 2-27. Location of Interrupt Jumpers (6- and 13-Slot Chassis)



There are two rows of pins in the header. The top row has 15 pins connected through the motherboard to the 15 interrupt levels of the processor. Additional pins on the top row are provided in the 13-slot chassis for special configurations, such as CRU expansion. The bottom row contains 48 pins in a 13-slot chassis or 20 pins in a 6-slot chassis. Two of these pins are wired to each of the possible circuit board interrupt outputs. This allows multiple interrupts to be connected to one interrupt level.

Interrupt pin assignments are shown in Figures 2-28 and 2-29, which are views of the jumper plugs as seen from the jumper wire side. The X marks identify jumper plug positions which have no corresponding pins on the header. The O marks identify jumper plug positions which have no corresponding pins on the earlier production header.

The configuration chart on top of the chassis details the interrupt level and chassis slot assignments. Any modifications should be recorded on the chart.

The detailed procedure for assigning and changing interrupt levels is presented in the hardware reference manual for the 990 computer (see preface). The information presented here is a brief summary of that procedure.

CAUTION

Do not remove or install any circuit board or modify any jumper while power is applied to the 990 processor.

To gain access to the interrupt jumpers, remove the circuit boards installed in slots 1 through 5. The interrupt jumpers will be visible on the motherboard just above the slot 1 connectors. The interrupt output of a full-sized board is on P2 of the assigned slot location. Therefore, if slot 8 is chosen for the controller, the interrupt output will be found at 8P2 of the wire-wrap pin header. A single jumper should be run from 8P2 pin to the selected interrupt level input to the processor. Level 9 is standard for Texas Instruments tape control software. A jumper is installed between 8P2 and level 9 as part of the standard 990 chassis configuration.

After completing any interrupt jumper modifications, carefully reinstall the removed circuit boards (component side up) according to the configuration chart fastened to the top of the computer. Update the configuration chart to correspond to the interrupt jumper modifications.

NOTE

System software is highly dependent on the interrupt structure of the computer. Any deviations from standard interrupt configurations must be brought to the attention of the system programmer before or during software installation.

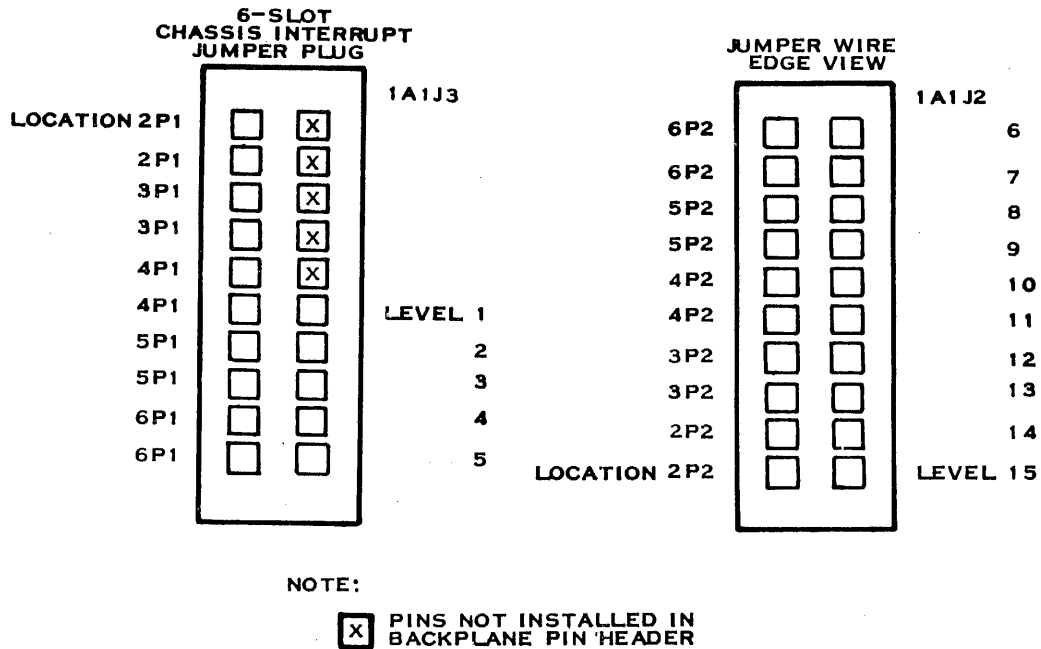

(A) 138673

Figure 2-28. 6-Slot Chassis Interrupt Jumper Plugs

2.4.3.4 Interrupt Connections for 17-Slot Chassis. Interrupt lines in the 17-slot chassis are wired to a 70-pin connector accessible from the rear of the chassis. A jumper assembly plugs into the connector to make the interrupt level to chassis slot connections. This assembly appears at the lower right of the chassis backplane as shown in Figure 2-25.

The jumper assembly is a PWB because it should not be necessary to alter the standard interrupt level assignments. If it should become necessary to change interrupt levels, the customer may purchase a special variable jumper assembly or modify the etch on the fixed jumper card. Figure 2-30 shows the pin assignments on the interrupt connector.

To gain access to the interrupt jumper assembly, open the chassis rear access cover as described in paragraph 2.4.3.2, steps 1, 2, 5, and 6. Observe all cautions and warnings.

Remove the interrupt jumper assembly by gently rocking it up and down to loosen the connector and then pulling straight back.

When reinstalling the assembly, make sure the pins are properly aligned before applying mating force.

CAUTION

It is possible to install the interrupt jumper assembly upside down. Note that pin 1 is at the bottom of the interrupt connector.

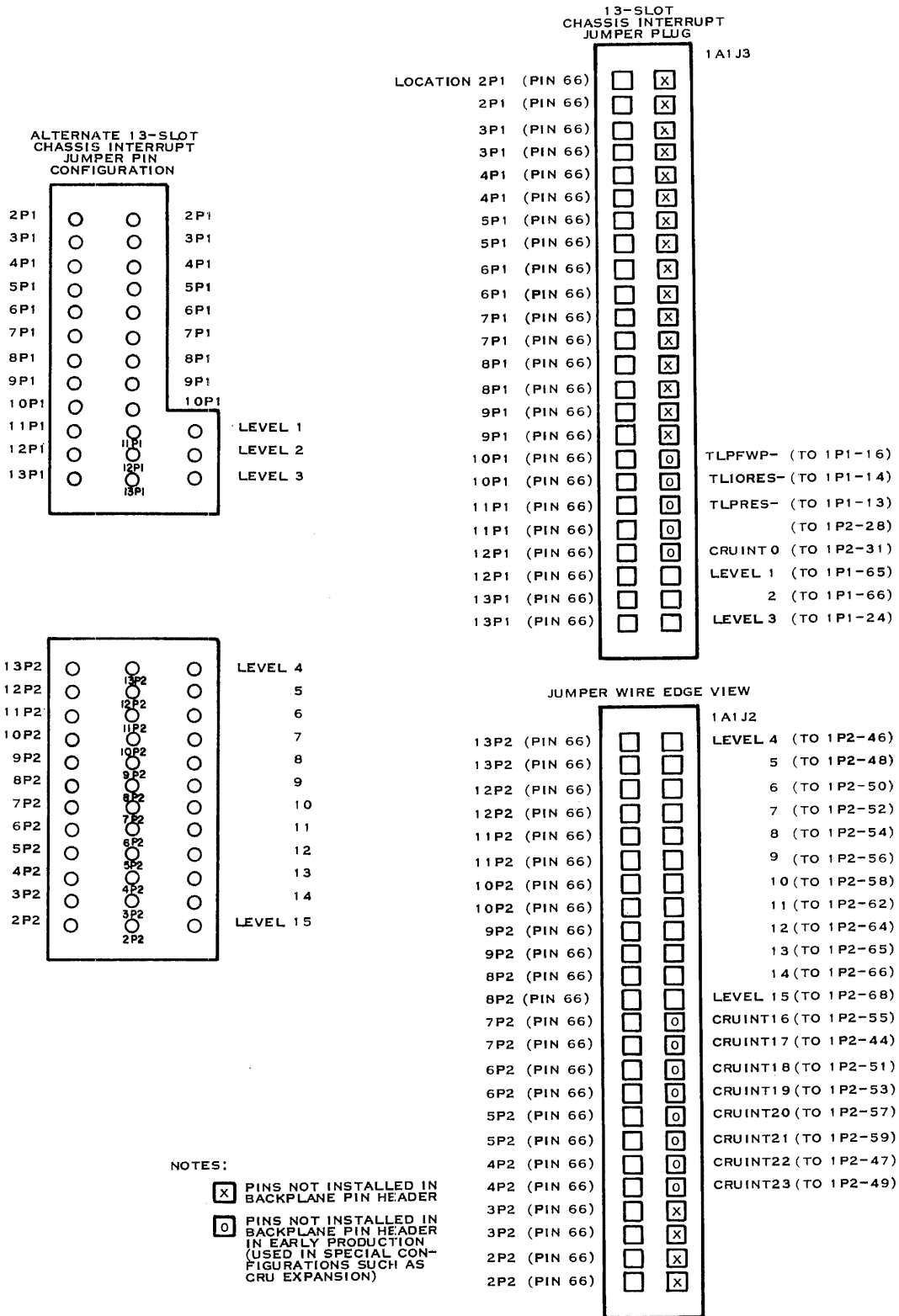

(A)138674

Figure 2-29. 13-Slot Chassis Interrupt Jumper Plugs

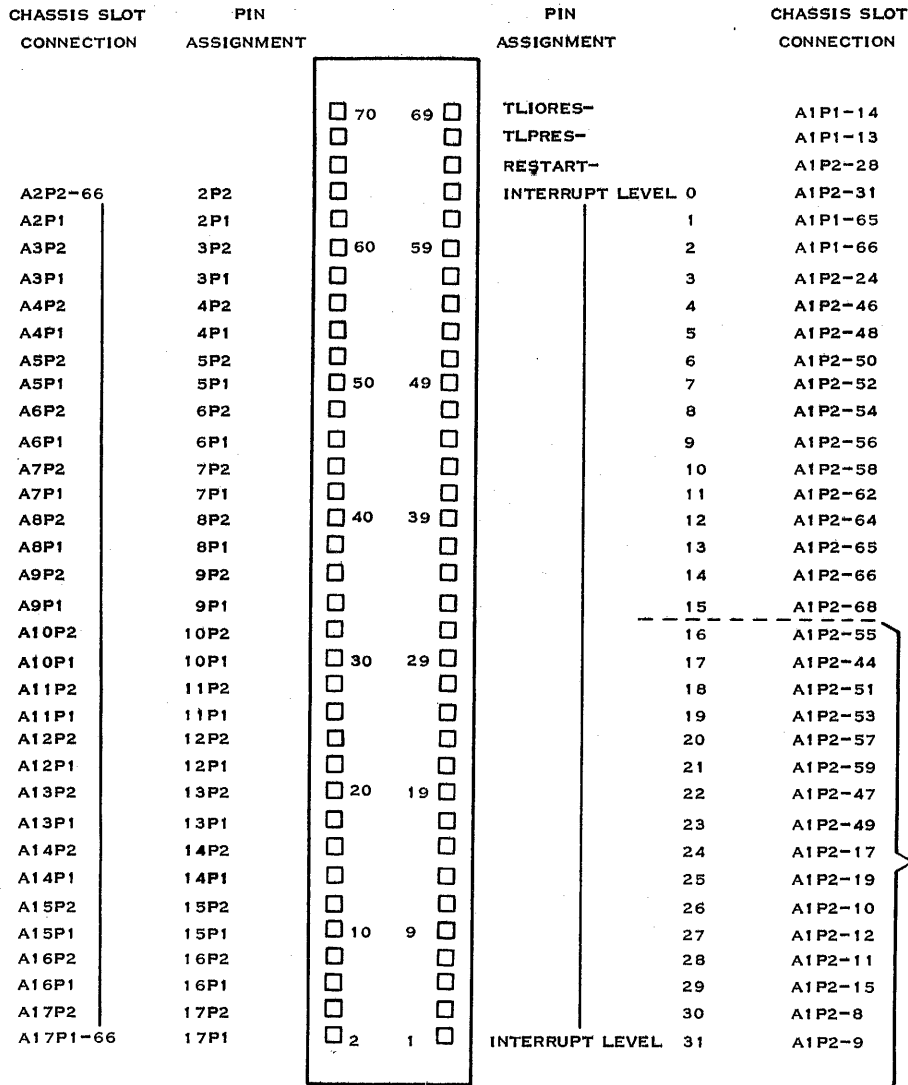

(A)141780

Figure 2-30. 17-Slot Interrupt Jumper Connector



2.4.4 PREPARATION OF DISK CONTROLLER. TILINE devices are assigned permanent addresses that the software programs use. The standard, factory-assigned TILINE address for the disk controller is >F800. The address can be changed by altering switch settings on the controller as described in the following paragraph.

2.4.4.1 Selecting Disk TILINE Address. The disk controller is assigned a TILINE slave address to allow the computer to communicate with the disk system. The address assignment is accomplished by selecting switch positions on the disk controller. The slave address switches are located on the component side of the PWB as shown in Figures 1-7 and 2-31. Sixteen addresses are possible, from >F800 through >F8F0 by changing the hexadecimal digits by setting the switches. Figure 2-32 illustrates the switches in more detail to show that TLADR 13-16 are changed by the switches to provide values of >0 through >F. Table 2-4 lists the correspondence between the switch settings and TILINE addresses.

2.4.5 INSTALLATION OF DISK CONTROLLER. With system power off, install the disk controller in the Model 990 Computer chassis slot 7 (or other slot that has been prepared in accordance with paragraph 2.4.3). Verify that the address switches on the controller are set to the correct TILINE address. For the 6- and 13-slot chassis, install the controller with the component side of the PWB toward the top of the computer chassis. Be sure that the controller is fully seated and the ejector tabs are locked in place. For the 17-slot chassis, install the board vertically with the component side to the right side of the chassis.

2.4.6 INSTALLING DISK SYSTEM INTERCONNECTION CABLES. The disk controller and the primary disk drive are interconnected with two 6.10-meter (20-foot) cables for the cabinet mount, or two 3.05-meter (10-foot) cables for the rack mount; and the primary and secondary disk drives are interconnected with two 1.83-meter (6.00-foot) ribbon cables.

The interconnection cable connectors and their mating counterparts on the disk controller and the disk drive cable adapter are not keyed. In early production models, a triangle is embossed on the top right end of each connector. When connecting the cables, ensure that the triangles on mating connectors are aligned as shown in Figure 2-33. Current production ribbon cable connectors have a very small groove depression (instead of a triangle) to align pin 1. Careful scrutiny in good light will reveal the notch depression. Figure 2-33 illustrates the connection of the 50-pin cable to the disk controller. The other interconnection cable connections are similar.

Following is the procedure for connecting the interconnection cables between the disk controller and the primary disk drive.

1. Align the cable connectors with the disk controller connectors as shown in Figure 2-33 and firmly mate the connectors.
2. Dress the cables backward along the right side of the Model 990 Computer chassis and secure with one of the cable hold-down clamps provided for this purpose as shown in Figure 2-34.
3. Route the cables to the rear of the disk drive observing the following guidelines:
 - a. Do not route the cable in a conduit that also houses ac power lines.
 - b. Do not route the cable through wet or damp areas.



946261-9701

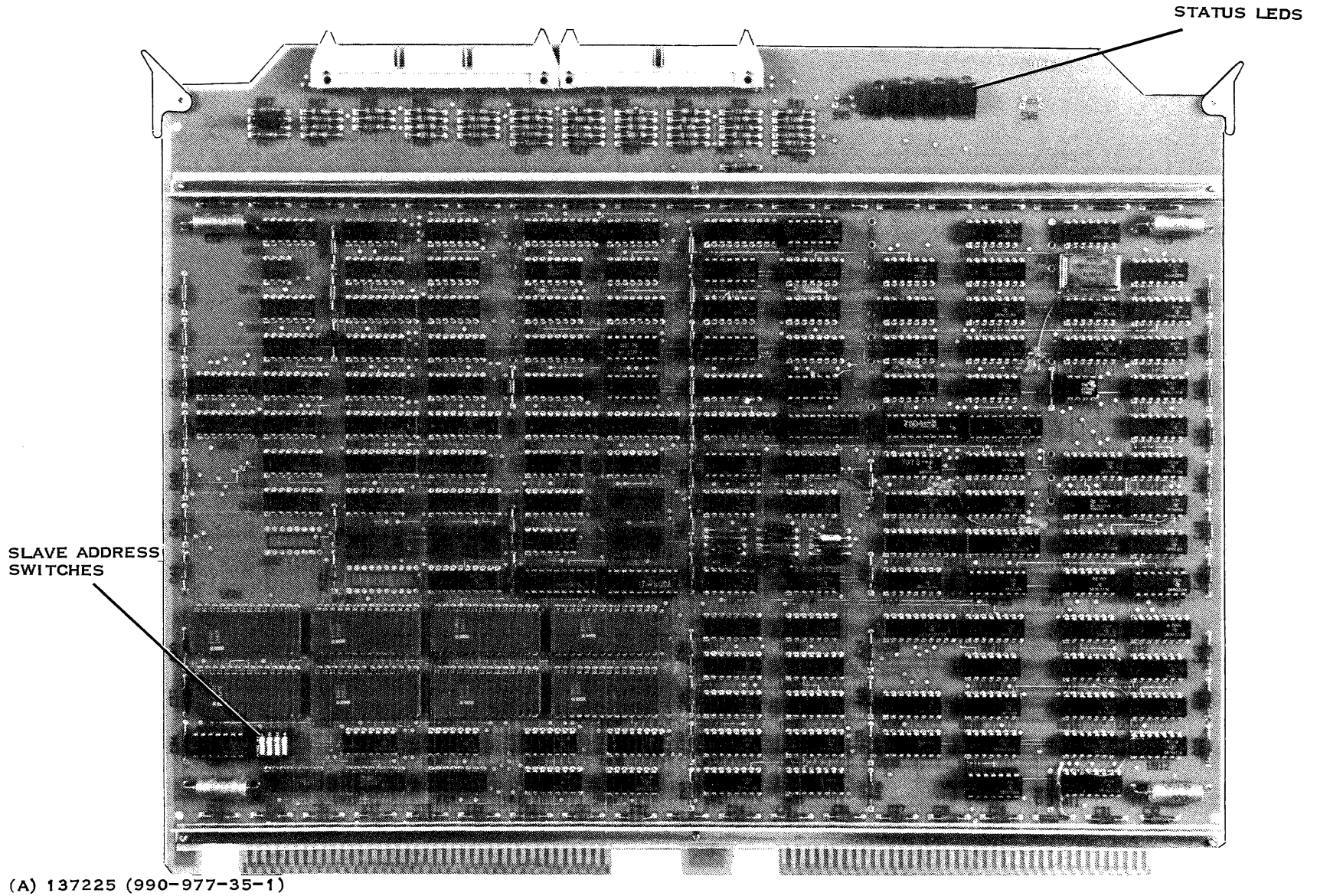
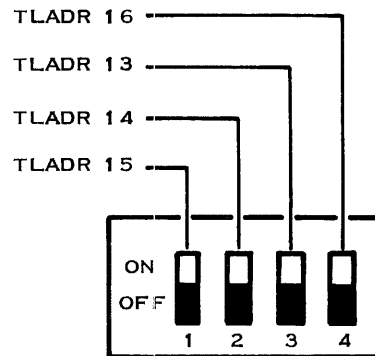

Figure 2-31. Model DS10 Cartridge Disk Controller (PWB)



(A) 137250

Figure 2-32. TILINE Slave Address Switches**Table 2-4. TILINE Slave Address Switch Settings and Addresses**

TILINE Address (Hex)	CPU Address (Hex)	Switches			
		1	2	3	4
FFC00	F800	Off	Off	Off	Off
FFC08	F810	Off	Off	Off	On
FFC10	F820	On	Off	Off	Off
FFC18	F830	On	Off	Off	On
FFC20	F840	Off	On	Off	Off
FFC28	F850	Off	On	Off	On
FFC30	F860	On	On	Off	Off
FFC38	F870	On	On	Off	On
FFC40	F880	Off	Off	On	Off
FFC48	F890	Off	Off	On	On
FFC50	F8A0	On	Off	On	Off
FFC58	F8B0	On	Off	On	On
FFC60	F8C0	Off	On	On	Off
FFC68	F8D0	Off	On	On	On
FFC70	F8E0	On	On	On	Off
FFC78	F8F0	On	On	On	On

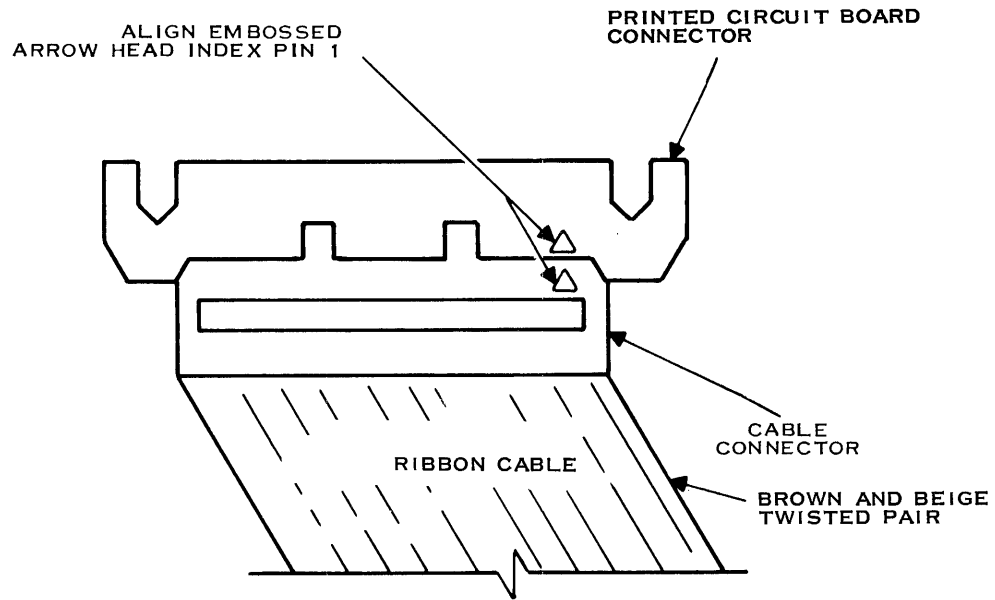

(A) FORMER CONFIGURATION

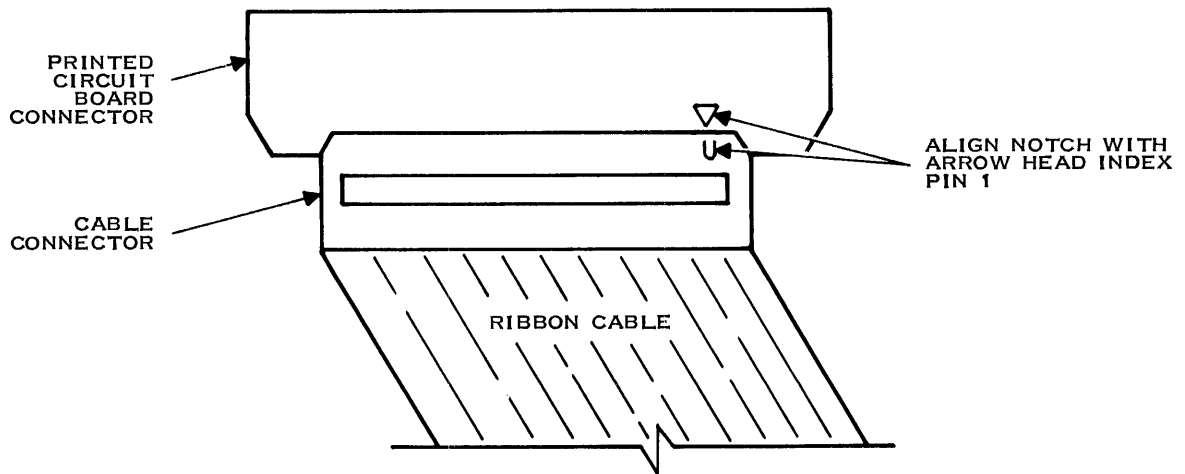

(B) NEW CONFIGURATION

(A)143516

Figure 2-33. Interconnection Cable Connector Mating

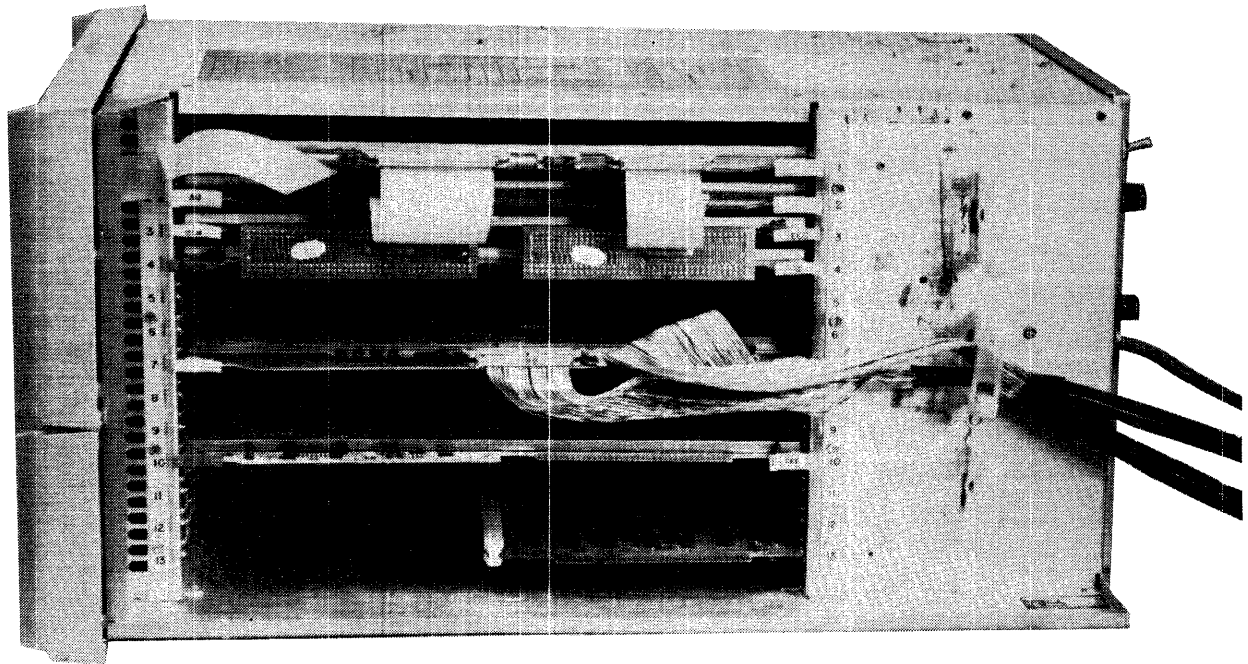

(A) 137252 (990-977-35-4)

Figure 2-34. Interconnection Cable Dressing in Computer Chassis

- c. Do not route the cable across traffic areas unless the cable is protected with a rigid wireway.
 - d. Allow sufficient slack at each end of the cable for easy connection of the cable to the unit.
4. Remove the cable adapter from the disk drive and insert the 40- and 50-pin ribbon cable connectors into one of the 40- and 50-pin cable adapter connectors shown in Figure 2-35. It makes no difference which of the connectors is used as long as there is a pin-to-pin correspondence and the connectors are aligned as described in the early portion of this paragraph. The remaining two connectors on the cable adapter are for daisy-chaining a secondary disk drive to the primary disk drive.
 5. If a secondary disk drive is to be connected, insert its cable connectors into the remaining two connectors on the cable adapter.
 6. Remove one screw completely from the strain relief strap on the cable adapter and loosen the other screw to allow free rotation of the strain relief strap.
 7. Reposition the strain relief strap across the cables so that the hole in its end is aligned with the hole in the cable adapter so that the screw removed in step 6 can be reinstalled.
 8. Reinstall the screw in the strain relief strap and tighten both strain relief screws tight enough to keep the cables from slipping under the strap.



9. Attach the cable carrier bracket in the disk drive by removing the two screws on the right of the input/output board and reinserting them through the bracket.
10. Mate cable adapter to disk drive connectors as oriented in Figure 2-35, and tighten retaining screws.
11. Slide disk drive forward so that cable retractor can be extended inside rack from disk drive to point where retractor is bolted to rack.
12. To prevent picking up power line noise in the signal cables, lay them flat against the cable carriers and dress the power cables along the top or bottom edge of the cable carrier (not internal to it) as shown in Figure 2-36, being sure to avoid routing the power cord on top of the ribbon cable. Use releasable cable ties to secure the cables. Allow enough slack at the hinges so the cables will not be strained when the cable carriers are flexed.

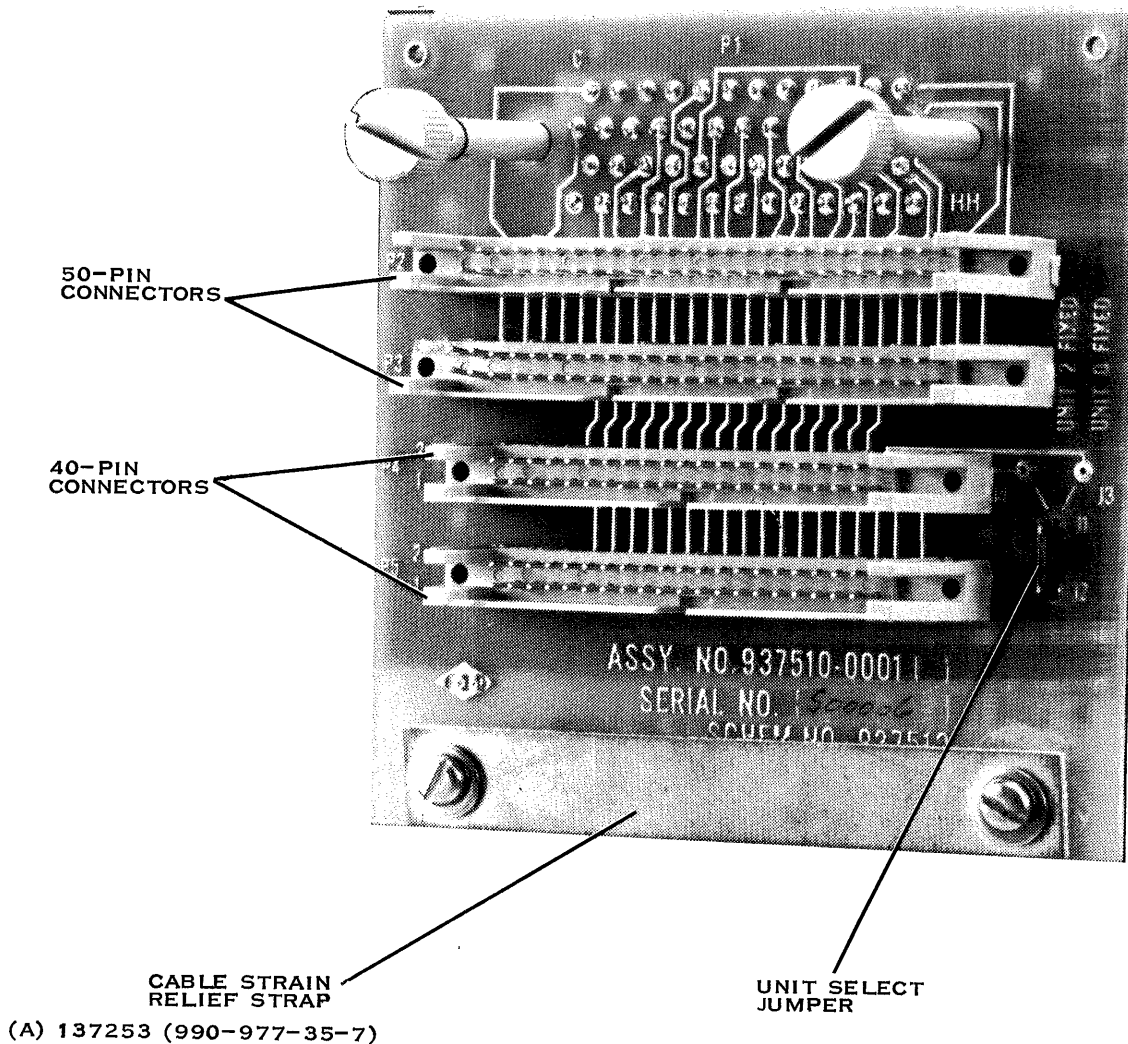
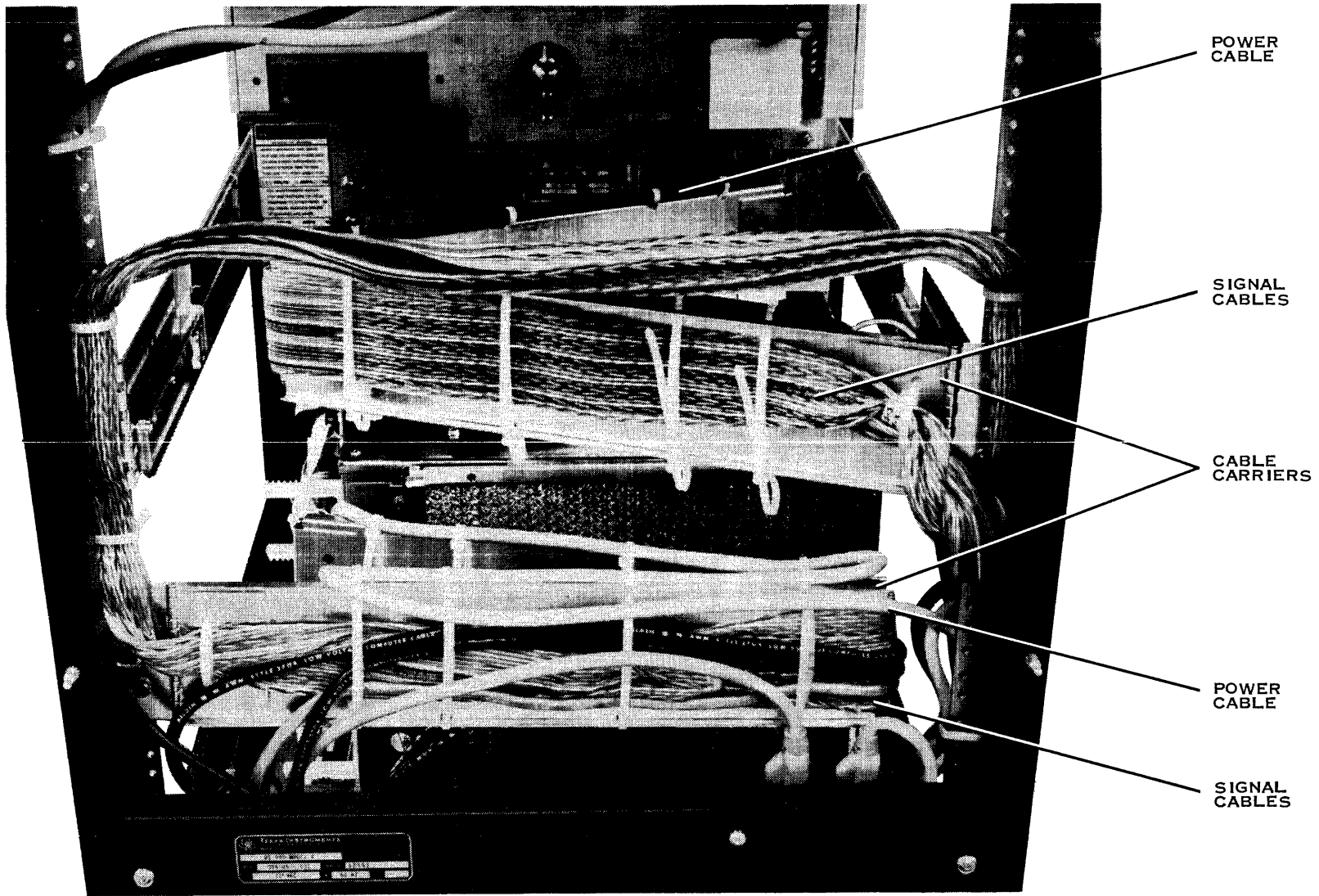

Figure 2-35. Cable Adapter



946261-9701



(A) 143666

Figure 2-36. Cable Arrangement on Cable Carriers



13. Replace rack backpanel.

If a secondary disk drive is to be connected into the system, proceed with the following steps.

14. Remove the resistor packs designated by XRM (n) in Figures 2-37 and 2-38 from the disk drive I/O board of the primary disk drive.

NOTES

Odd-numbered terminators (XRM 1,3, . . .11) are 110-ohm networks. Even-numbered terminators (XRM 2,4, . . .12) are 330-ohm networks.

When two drives are daisy-chained, only one set of terminating resistors is permitted. The resistor packages must be removed from one disk drive (normally the drive connected to the controller). On the drive without terminating resistors, two 220 PF capacitors must be installed on XRM 8, pins 1 to 16 and 2 to 15. Trim capacitor leads to about three-eighths inch.

The capacitors are included in a bag with the secondary disk drive kit.

15. Set the switches on the primary and secondary disk drive I/O boards as shown in Figures 2-39 and 2-40. Note that for the secondary drive, S1-1 and S2-1 are turned off and S1-2 (unit select 2) and S2-2 (interrupt 2) are turned on.
16. Connect cable adapter to primary disk drive as shown in step 6.

2.4.7 CONNECTION OF DISK DRIVE TO AC POWER SOURCE. The following procedure should be observed to connect the disk drive to ac power after all the preceding procedures of this section have been completed. Refer to Figure 2-41 for the procedure.

1. Plug ac power cord into nearest ac outlet providing proper voltage and line frequency (specified in Section 1).

NOTE

Apply power to the secondary disk drive first, so that power is supplied to the terminator before it is supplied to the primary disk drive. A primary disk drive fault may occur if terminator power is not present.

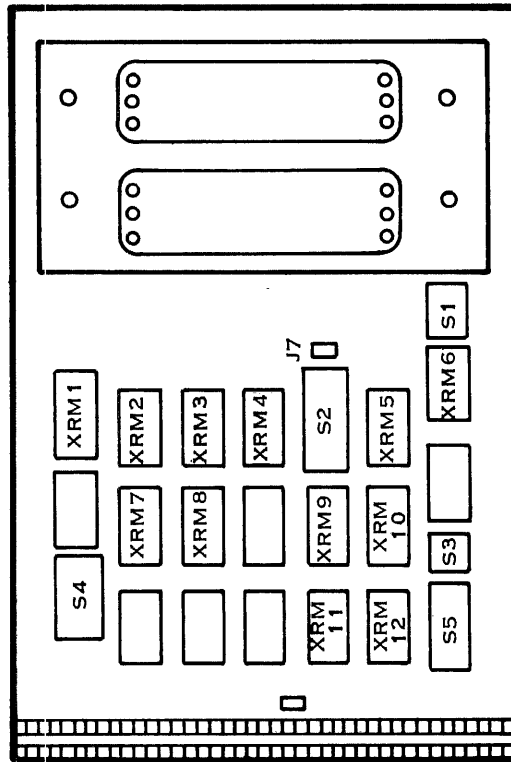

(A)137254

Figure 2-37. XRM (n) Resistor Packs to be Removed from Primary Rack Mount Disk Drive I/O Board

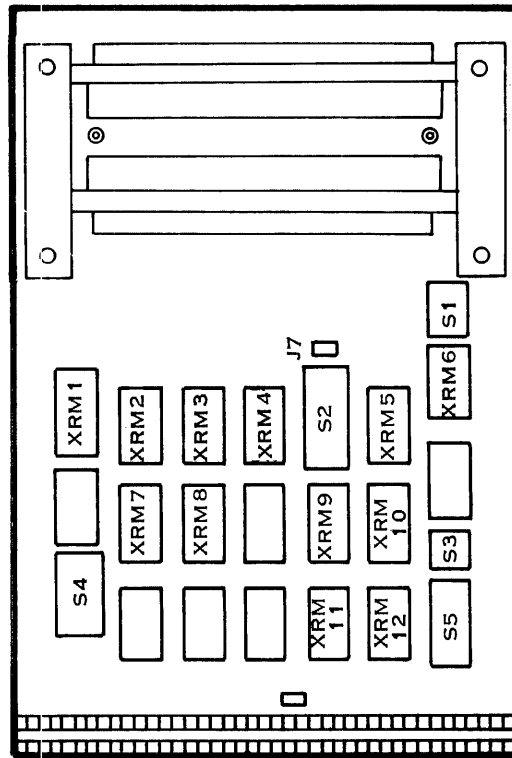

(A)137255

Figure 2-38. XRM (n) Resistor Packs to be Removed from Primary Cabinet Mount Disk Drive I/O Board



2. Set the dc circuit breaker (labeled 34 VOLTS) to ON. The breaker toggle is located behind the semicircular protective flange.

NOTE

Set the dc circuit breaker before setting the ac circuit breaker (following step) or the ac breaker will not set.

3. Set the ac circuit breaker (labeled MAIN) to ON. Fan should start.

2.4.8 DISK CARTRIDGE INSTALLATION AND REMOVAL. Before installing or removing a disk cartridge from the disk drive, be sure that the spindle of the disk drive is not rotating. Do not attempt to install or remove a cartridge unless the brush indicator on top of the disk drive is aligned with the black area as shown in Figure 2-42. A coin or screwdriver may be used to make the alignment.

2.4.8.1 Purging the Disk Drive Air Filtering System. Before installing the drive on the system but after inspection and power configuration, it is necessary to purge the air filtering system to assure that any residual dust or contamination is removed.

This is accomplished by performing the following steps.

1. Set the MAIN circuit breaker to OFF.
2. Unplug A1P2 on the actuator.
3. Install a scratch cartridge (see paragraph 2.4.8.2).
4. Set the MAIN circuit breaker to ON.
5. Set the START/STOP switch to ON.
6. Allow the disk to spin and run with the heads retracted for 30 minutes.



7. Set the START/STOP switch to STOP.
8. Reconnect A1P2.
9. Remove the scratch cartridge (see paragraph 2.4.8.3).

2.4.8.2 Disk Cartridge Installation.

1. Raise cartridge access door (cabinet mount) or pull disk drive out of rack (rack mount).

NOTE

Power must be on and START/STOP lamp must be extinguished to release lock on hold-down arms.

Refer to Figure 2-43 for the remainder of this procedure.

2. Pull back hold-down arms.
3. Set disk cartridge upright on a firm supportive surface.

NOTE

There are two types of disk cartridge available. One type has a dust cover lock that disengages when the slide button is moved to the left. The other type disengages the lock when the slide button is pushed towards center.

4. Push disk cartridge cover release button to left, or towards the center, depending on the type of cartridge, while lifting cartridge handle to separate dust cover and disk.
5. Disengage dust cover from disk. Set cover aside.

CAUTION

Do not make abrasive contact between disk and spindle. Ensure that the read/write heads are fully retracted and the brushes are completely out of the disk area. Remove any dust from magnetic chuck.

6. Position head opening of disk toward rear of disk drive and place disk onto spindle hub.

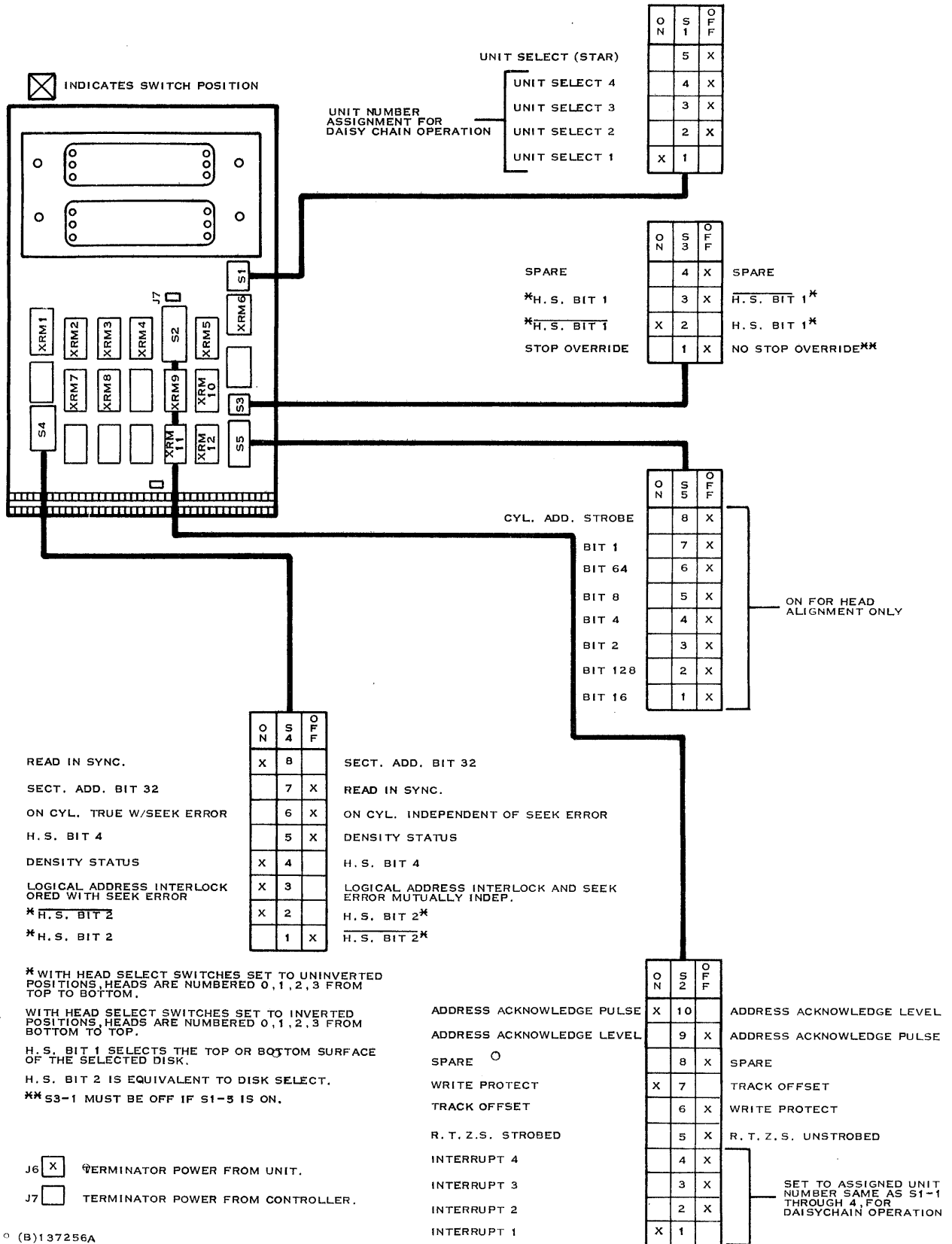

Figure 2-39. Switches and Settings for Rack Mount Primary Disk Drive

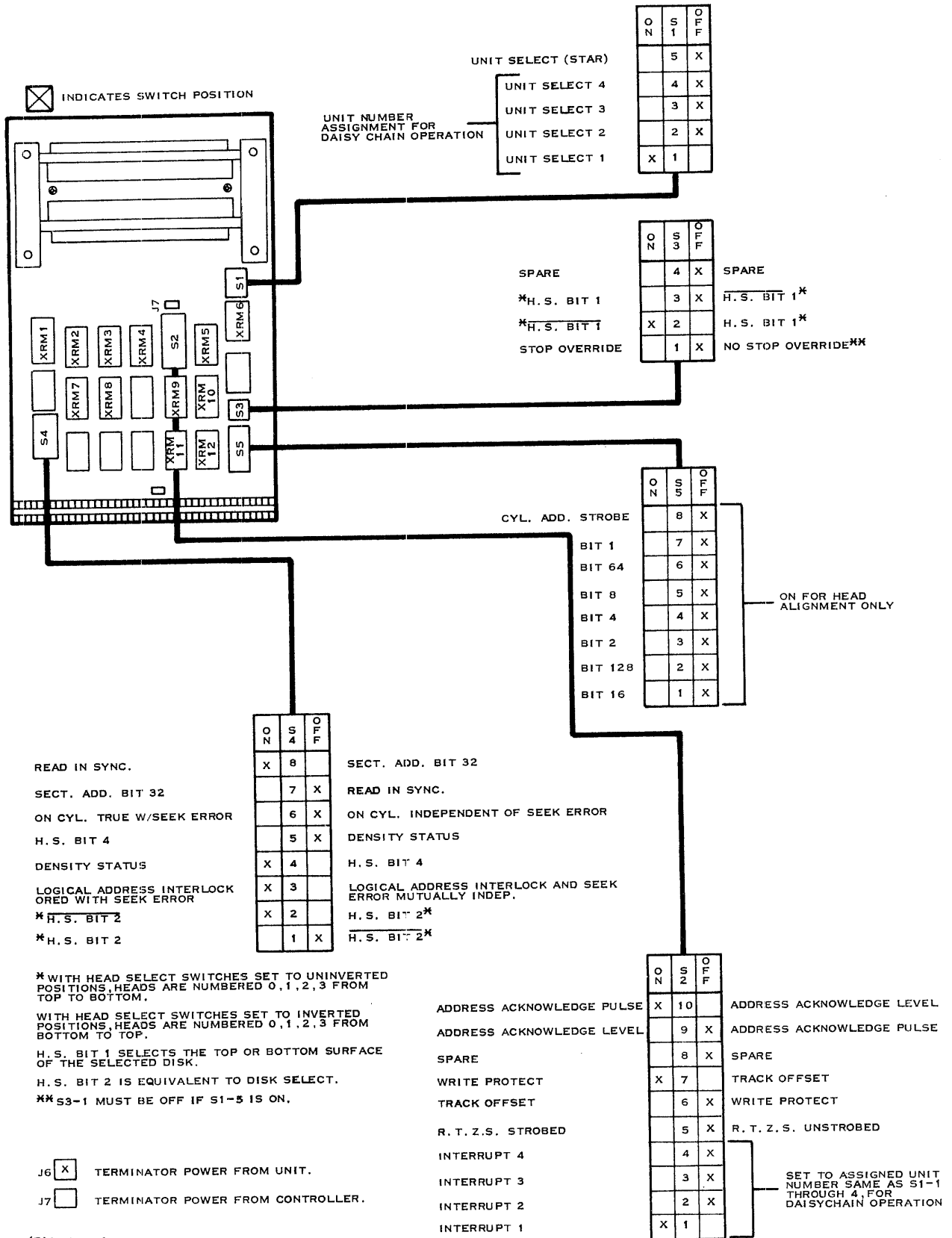
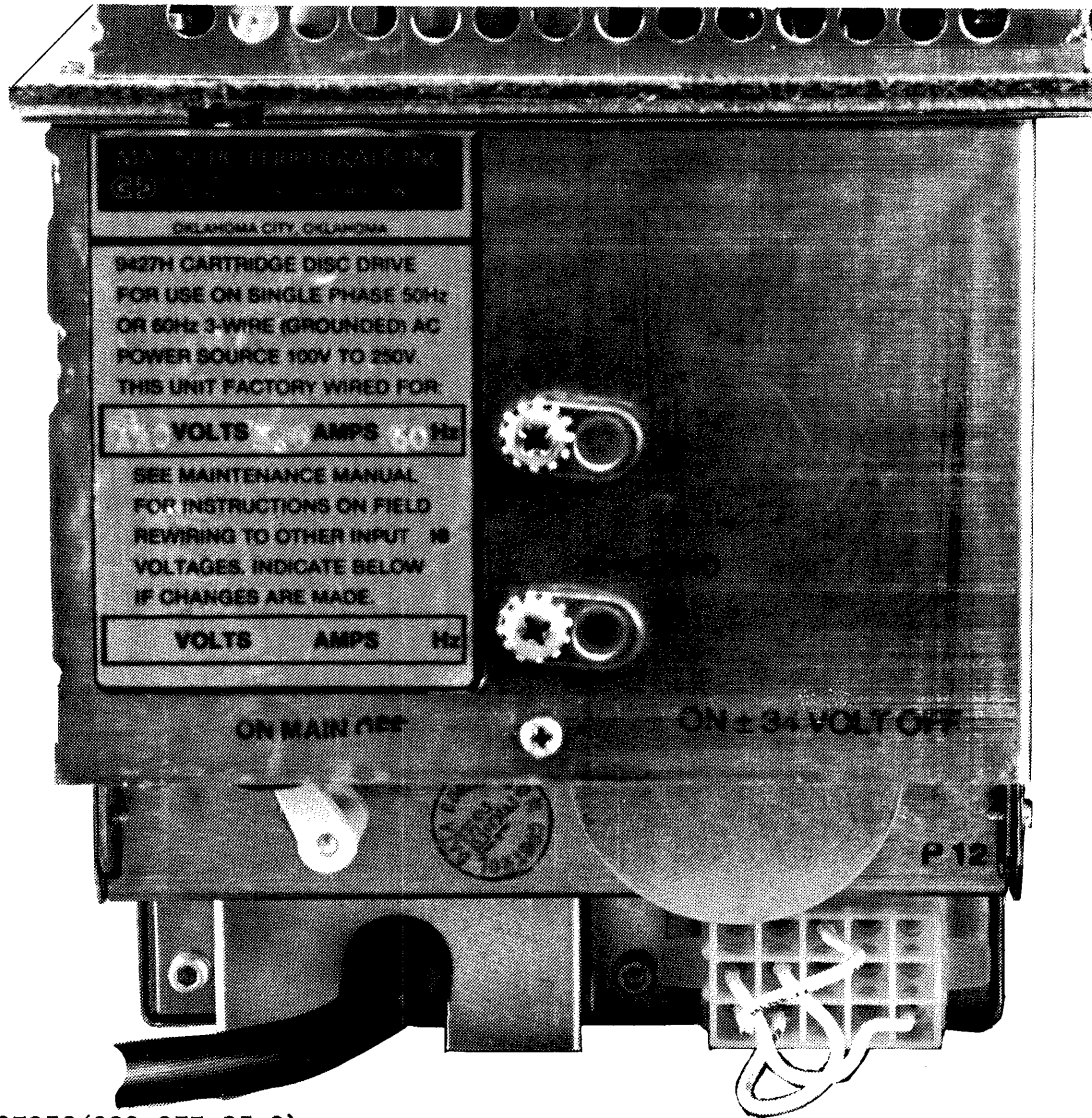
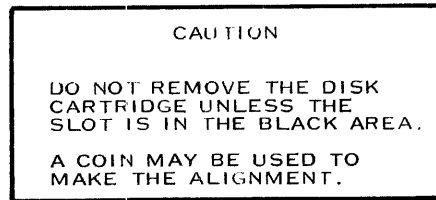

Figure 2-40. Switches and Settings for Cabinet Mount Primary Disk Drive



(A) 137258 (990-977-35-2)

Figure 2-41. Disk Drive Circuit Breakers



(A) 137259

Figure 2-42. Brush Indicator

7. Rotate cartridge slowly back and forth until cartridge seats over spindle.
8. Turn handle down to seat cartridge.
9. Place dust cover (removed in step 5) open end down over cartridge.
10. Position hold-down arms over cartridge and dust cover.
11. Close cartridge access door (cabinet mount) or push disk drive into rack (rack mount).

2.4.8.3 Disk Cartridge Removal. Refer to Figure 2-43 for the following procedures.

1. Press START/STOP switch and wait for START/STOP indicator to be extinguished.

CAUTION

If START/STOP indicator is still illuminated after 2-1/2 minutes and brushes are not fully retracted, contact the customer service engineer.

2. Raise cartridge access door (cabinet mount) or pull disk drive out of rack (rack mount).
3. Pull back hold-down arms (arms will not move until cartridge rotation has stopped and START/STOP indicator is extinguished).
4. Remove cartridge dust cover.
5. Push cartridge release button to left, or towards the center, while lifting cartridge up and out of disk drive by handle.
6. Place cartridge inside dust cover and fold down handle until a snap is heard indicating that the cartridge and dust cover are locked together, or slide the release button away from the center.
7. Close cartridge access door (cabinet mount) or push disk drive back into rack (rack mount).

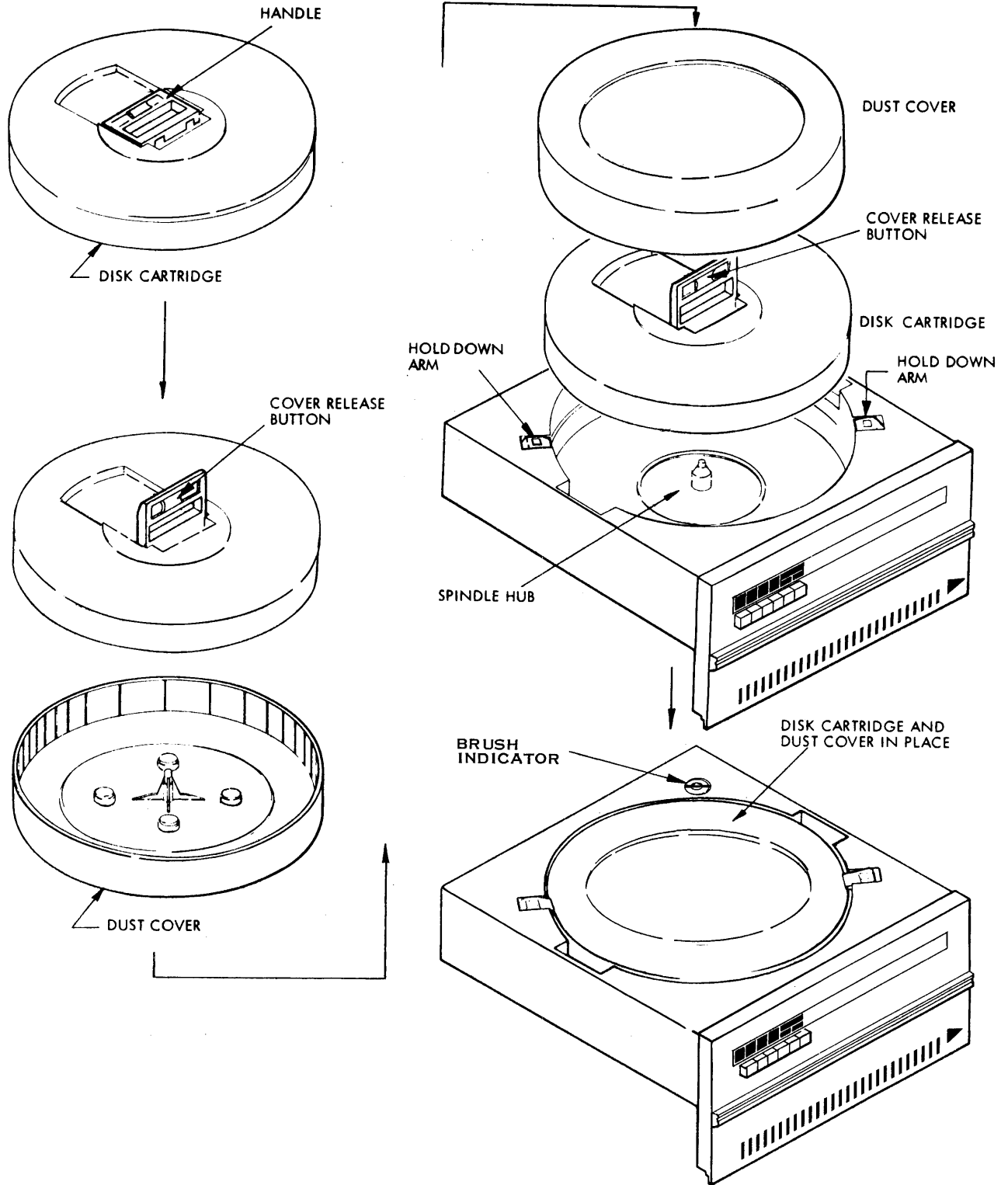

(A) 137260A

Figure 2-43. Disk Cartridge Installation

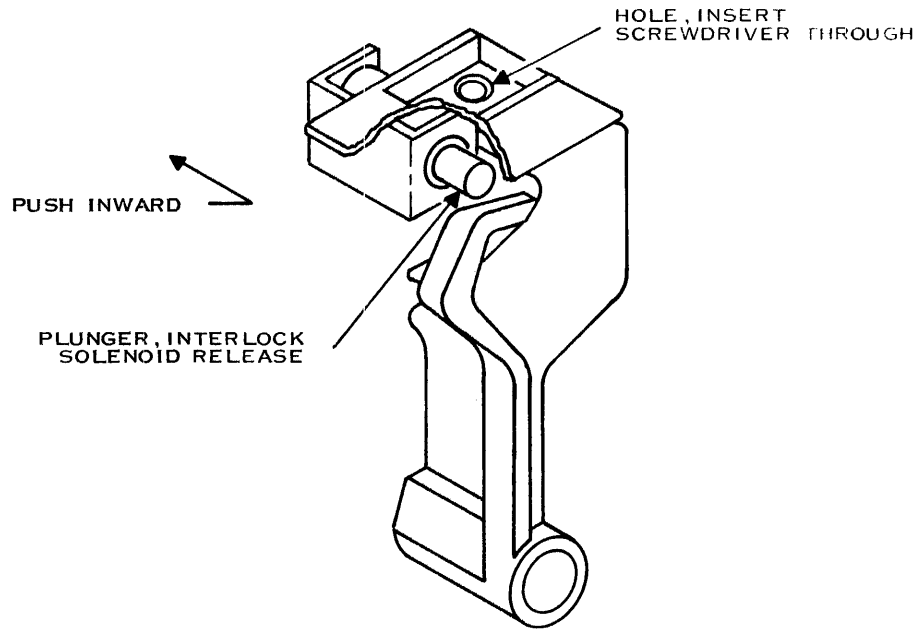

(A) 137261

Figure 2-44. Cartridge Locks**NOTE**

If no cartridge is to be installed for any long period of time, install the dust cover received with the disk drive.

2.4.8.4 Removal of Disk Cartridge Following Power Failure or for Emergency. Removal of the disk cartridge following power failure or in an emergency situation should be performed only by the customer service engineer.

1. Wait approximately three minutes for cartridge to stop spinning.
2. Raise cartridge access cover (cabinet mount) or pull disk drive out of rack (rack mount).
3. Release pack locks by inserting a flat head screwdriver (or similar object) into hole on top of pack lock (see Figure 2-44). Press solenoid plunger into solenoid and tilt pack lock.
4. Pull back hold-down arms.
5. Remove cartridge dust cover.



6. Lift cartridge handle, hold cover release button to left, or towards the center, and lift cartridge up and out of disk drive by handle.
7. Place cartridge inside dust cover and fold down handle until a snap is heard indicating that the cartridge and dust cover are locked together, or slide release button away from the center.
8. Close cartridge access door (cabinet mount) or push disk drive back into rack (rack mount).

2.5 SYSTEM OPERATIONAL CHECKOUT

After connecting all cables and applying power to the system, but before installing any software service routine in the computer, perform the following procedure to ensure that the disk system is operational.

1. Install a disk cartridge into the disk drive according to the procedure in paragraph 2.4.8.2.
2. Press START/STOP switch to start spindle motor. Observe the START/STOP indicator is illuminated and that the sound of the spindle motor can be heard. Observe that brush indicator rotates slowly 90 degrees, then returns to normal position.
3. Ensure that READY indicator is illuminated within at least 70 seconds.
4. Allow disk drive and disk cartridge to reach thermal stabilization (approximately 20 minutes).
5. Load and execute performance demonstration test in accordance with the appropriate section of *Model 990 Computer Diagnostics Handbook*.
6. If performance demonstration test or any of the above steps fails, notify the customer service engineer.



SECTION 3

PROGRAMMING

3.1 GENERAL

This section provides information for the programmer to control the disk system using assigned control words. Paragraphs 3.2, 3.3, and 3.4 provide general information about issuing commands and interrupts, and about command completion. Paragraph 3.5 describes in detail the contents and formats of the eight control words in Figure 3-1 that are used in programming the disk controller.

Finally, paragraph 3.6 provides hardware and firmware terminology definitions and describes the data formats that are processed by the disk controller. The programmer should refer to paragraph 3.6 before attempting to write a software program if he is unfamiliar with the terminology and data formats of the controller for the disk system.

3.2 PROGRAMMING THE DISK CONTROLLER

Program control of the disk system is relatively simple. To issue a command to the disk system, the programmer moves eight words to the disk controller over the TILINE bus in the same way that a word is moved to the memory of the Model 990 Computer. Any computer commands that read or modify memory can be used to communicate with the controller. The controller is assigned a block of memory addresses just as any other memory module. The controller can accept eight consecutive memory addresses.

The TILINE address for the controller is selected by a switch package on the controller as shown in Figure 2-15. A total of 16 possible starting TILINE addresses can be selected. The possible range of starting TILINE addresses is from >FFC00 through >FFC78 (CPU addresses >F800 through >F8F0).

3.3 COMMAND CONTROL

The disk controller is initiated and interrogated by a TILINE master (normally the computer's CPU) via a set of control words. These eight control words and their corresponding TILINE addresses are shown in Figure 3-1 and described in the following paragraphs.

An attempt by the software to write certain bits of the disk system hardware register that are not assigned a meaning results in a normal cycle with no effect on the operation. When the controller is busy (in a not idle state), any attempt to read or write is aborted as the controller responds with TLTM- (TILINE terminate). When the controller is busy, no data transfer occurs for a write cycle; and for a read cycle, bit zero is returned as logic zero when the controller is busy. For a read command during a busy cycle, bits 1 through 15 are indeterminate (may be either one or zero).

3.4 COMMAND COMPLETION

The disk controller can be programmed to issue interrupts. This capability is implemented to make this disk controller compatible with other disk controllers. The interrupt capability is implemented by having the controller issue an interrupt whenever a mask bit in the controller register R0 is set while in the idle mode or by issuing an interrupt upon return to idle provided the interrupt enable has been set.

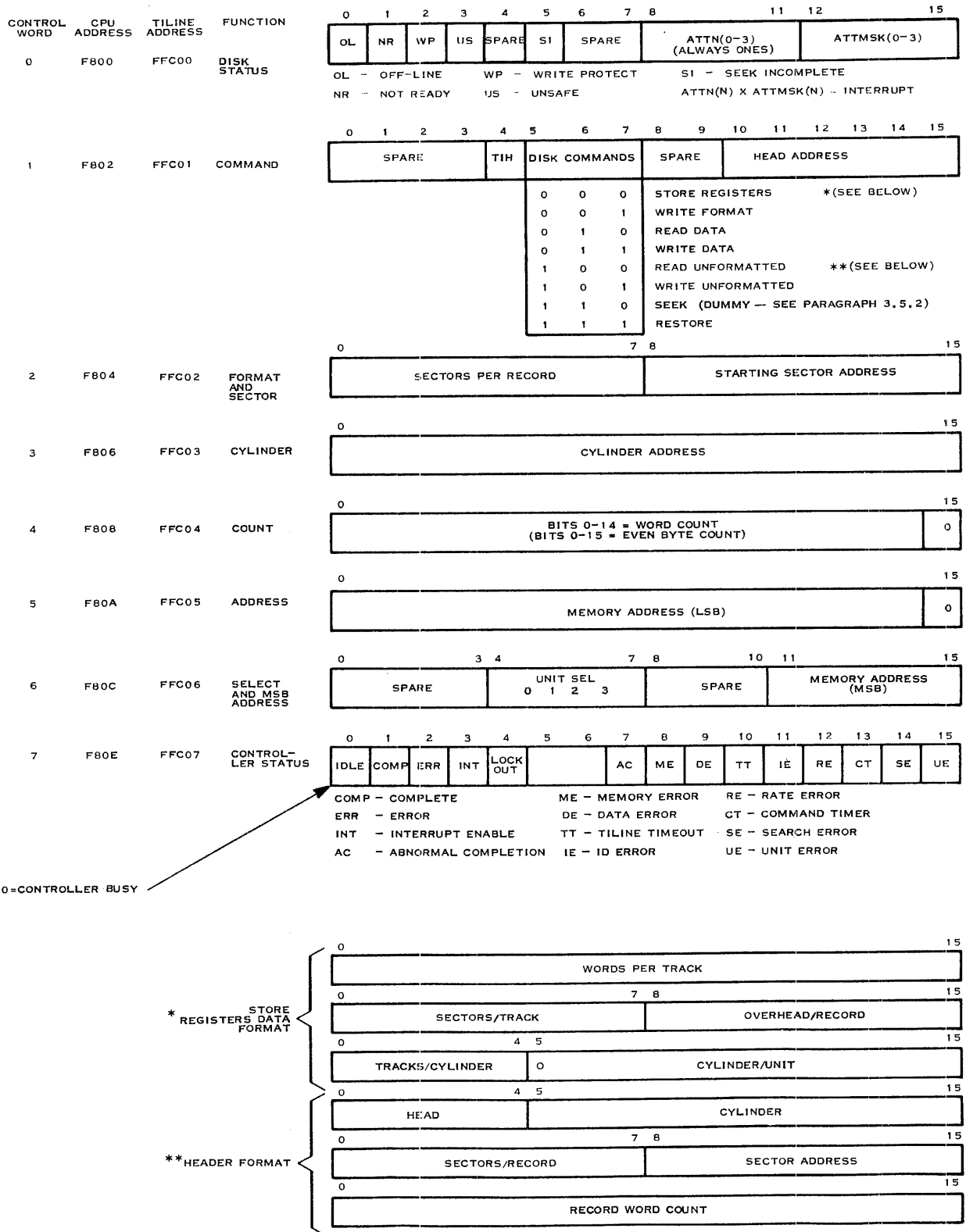

(B)132878

Figure 3-1. Model DS10 Disk System Control Word Formats



3.4.1 COMMAND COMPLETION WITHOUT INTERRUPTS. If interrupts are not used, the computer program can determine if the controller has completed a command by reading bit 0 of control word 7. If bit 0 (idle) is zero, the disk controller is busy. When a command is complete, the idle bit and either the error bit or the complete bit is set. If lockout is being used, it is set after control word 7 is read, and if the error bit was set, an error status bit is set.

3.4.2 COMMAND COMPLETION WITH INTERRUPTS. The controller issues two kinds of interrupts to the computer. One interrupt is issued when the controller completes a command, and one when the disk is issued a seek or restore command (interrupt given immediately after return to idle state with interrupt mask bit set).

3.4.2.1 Command Completion Interrupts. In order to have the controller signal the completion of a command by issuing an interrupt to the computer, the computer program sets the interrupt bit of control word 7 (bit 3) at the same time the command is started by resetting the idle bit (bit 0). When the controller returns to idle, an interrupt is issued when the controller detects either the complete or error bit set with interrupt enabled. The interrupt is cleared by resetting interrupt enable in R7.

3.4.2.2 Seek and Restore Completion Interrupts. Control word 0 contains four attention bits and four attention mask bits. The attention bits are not used by this disk controller. They are, instead, forced to logic one whenever register R0 is read. The programmer can set or reset the mask bits by using any of the computer memory instructions.

The correct way to use the control word 0 interrupts is to issue the seek or restore command to the controller; then, after the controller reports completion, set the correct mask bit. When the disk drive finished the dummy seek operation, an interrupt is issued to the computer. The interrupt can then be cleared by resetting the mask bit. The TILINE interrupt is always reset when the controller goes from an idle to a busy condition. The controller will not execute an independent seek command. It accepts the command, goes through initialization and self diagnostics, then terminates with operation complete so that interrupts are handled the same.

3.5 CONTROL WORD CONTENT AND FORMATS

The eight control words shown in Figure 3-1 are used by the programmer to direct the activities of the disk drive. The format, content, and activities of each of these control words are described in the following paragraphs.

3.5.1 DISK STATUS, CONTROL WORD 0. When the controller is not busy, the disk status of control word 0 can be used. Figure 3-2 shows the bits of control word 0 (disk status).

Bits 0 through 5 of control word 0 contain individual status indicators from the selected disk drive. Bits 8 through 11 are forced to logic 1. The bits are defined as follows.

Bit 0, Offline (OL). When bit 0 is set, it indicates that there is no power to the selected disk drive, the drive is not at the proper speed, or not loaded with a disk cartridge, or that an unsafe condition exists.

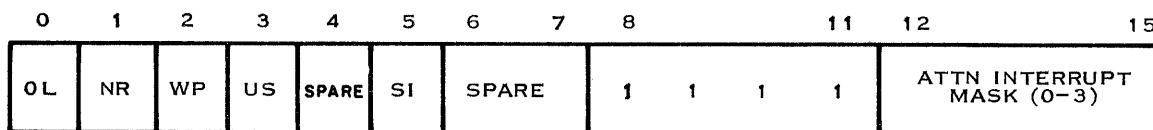

(A) 133992A

Figure 3-2. Control Word 0

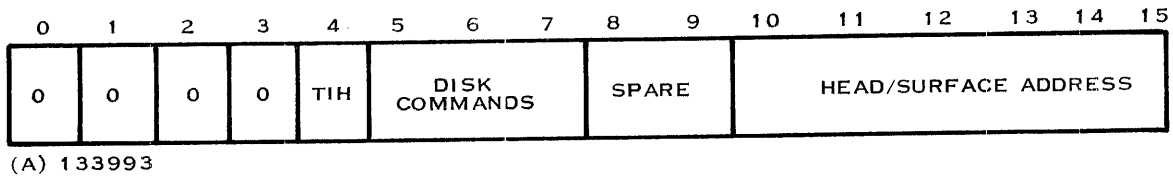

Figure 3-3. Control Word 1

Bit 1, Not Ready (NR). When bit 1 is set, it indicates that the selected disk drive is in the process of performing a seek operation, or that the heads are not loaded.

Bit 2, Write Protect (WP). When bit 2 is set, it indicates that the write protect status (WRITE/PROTECT CART switch or WRITE/PROTECT FIXED switch) of the selected disk drive is on. When this switch is on, it inhibits the write logic within the disk drive.

Bit 3, Unsafe (US). When bit 3 is set, it indicates that the selected disk drive is unsafe. This means that the safety circuits that protect the recorded information are unsafe, and the unsafe condition must be removed before any more commands are attempted. If an unsafe condition occurs, the FAULT switch on the selected disk drive can be used to clear the fault condition provided the condition has ceased. A restore command can also be issued to clear the fault condition.

Bit 5, Seek Incomplete (SI). When bit 5 is set, it indicates that the selected disk drive has failed to complete a seek operation because of a disk malfunction or detection of an illegal cylinder address (illegal address interlock). When this status is detected, the software must initiate a restore command before attempting to execute any other command.

Bits 8 through 11. Bits 8 through 11 are not used and are forced to logic 1 because overlapped seeking of logical units is prohibited.

Bits 12 through 15, Attention Interrupt Mask (0-3). These bits cause an interrupt when set to logic 1. The TILINE interrupt is set when the attention interrupt mask is on and the controller is idle. Software can disable the interrupt source by clearing the interrupt mask bits.

3.5.2 COMMAND CONTROL, CONTROL WORD 1. Control Word 1 is used for disk commands and surface selection. Figure 3-3 shows the bits of control word 1. The bits of control word 1 are defined as follows:

Bit 4, Transfer Inhibit (TIH). When bit 4 is set, the controller will not transfer any disk words into memory when a read data command is specified. The purpose of this bit is to allow data verification by relying on the cyclical redundancy character (CRC) check without having to provide a buffer in memory for the specified block. After the read data command is completed, this bit is reset by the computer.

Bits 5 through 7, Command. These three bits are a 3-bit code that designates a command (one of the eight commands illustrated in Figure 3-1). The bits and the commands they specify are listed in Table 3-1 and described as follows:

NOTE

Details of the contents, format, and programming procedures for the disk commands are provided later in this section. Refer to paragraph 3.5.9.



Table 3-1. Disk Command Bits

Bits	Command
5 6 7	
0 0 0	Store Registers
0 0 1	Write Format
0 1 0	Read Data
0 1 1	Write Data
1 0 0	Unformat Read
1 0 1	Unformat Write
1 1 0	Seek
1 1 1	Restore

- **Store Registers (000)** — Used to ascertain which disk drive is connected to the controller and to establish parameters for the particular disk.
- **Write Format (001)** — Used for formatting or reformatting a single track.
- **Read Data (010)** — Reads formatted data from disk and transfers the data to the specified TILINE address.
- **Write Data (011)** — Transfers data from a TILINE address and controls formatted data being written on disk.
- **Unformat Read (100)** — Reads data from disk without regard to record ID or record boundaries and transfers the data to the specified TILINE address.
- **Unformat Write (101)** — Transfers data from a TILINE address and writes the data on the disk without regard to record boundaries.
- **Seek (110)** — Dummy command that is accepted and completed normally but does not actually move heads.
- **Restore (111)** — Positions the head over cylinder 0. A restore is implemented by a full stroke movement by disk.

Bits 8 and 9. Bits 8 and 9 are not used and are forced to logic 0.

Bits 10 through 15, Head Address. The field consisting of bits 10 through 15 selects one of the two read/write heads.

3.5.3 FORMAT AND SECTOR, CONTROL WORD 2. Control word 2 is used to indicate the number of sectors per record and the address of the sector. The bits of this control word are shown in Figure 3-4 and defined as follows:

Bits 0 through 7, Sectors Per Record. A disk can be formatted into variable length data records with a fixed number of sectors per record for a given track. Bits 0 through 7 of Control Word 2 specify the number of sectors per record. The number of sectors per record multiplied by the number of records per track will not exceed the fixed number of sectors per track of a particular disk drive. Format calculations are given in paragraph 3.6.1.

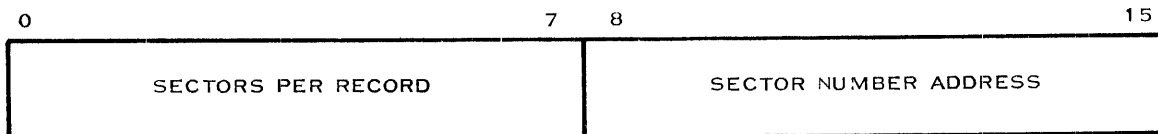

(A) 133994

Figure 3-4. Control Word 2

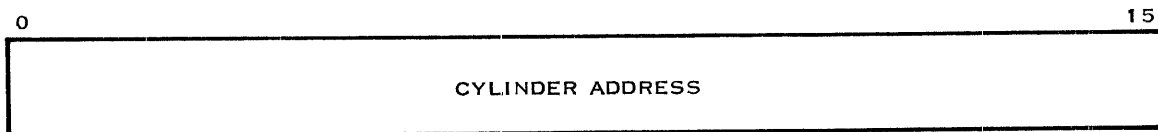

(A) 133995

Figure 3-5. Control Word 3

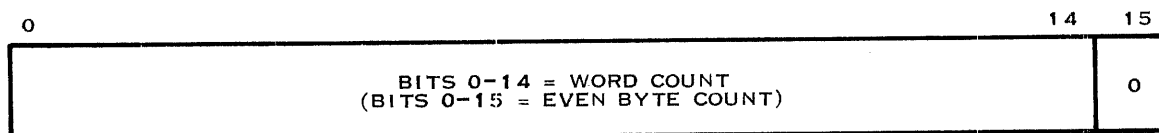

(A) 133996

Figure 3-6. Control Word 4

Bits 8 through 15, Sector Address. This field selects the sector number at which the controller starts a read or write operation. The controller adds the sectors per record (bits 0 through 7) to the starting record address to calculate the address of subsequent data records on a track when multiple records are transferred. The range of sector addresses is >00 through >13.

NOTE

If the sectors per record for a track does not equal one, then the programmer must be sure that sector addresses that correspond to record boundaries are used.

A sector address larger than the maximum sector address results in a timeout status because the controller cannot find a starting sector number at which to start executing the command. A sectors per record command exceeding maximum sector size will be detected on initialization and will cause the controller to trap to command timeout status.

3.5.4 CYLINDERS, CONTROL WORD 3. The cylinder address is selected by bits 0 through 15 of control word 3. Figure 3-5 illustrates control word 3. The valid number range is >0000 through >0197. An invalid cylinder address results in a termination and unit error controller status being set. The disk status (control word 0) will indicate seek incomplete.

3.5.5 WORD COUNT, CONTROL WORD 4. The word count is controlled by control word 4 as shown in Figure 3-6. For data commands, this field selects the number of 16-bit data words to be transferred between the disk and the TILINE. The number of words is limited by the available TILINE memory and the disk memory from the starting disk address to the last sector of the last

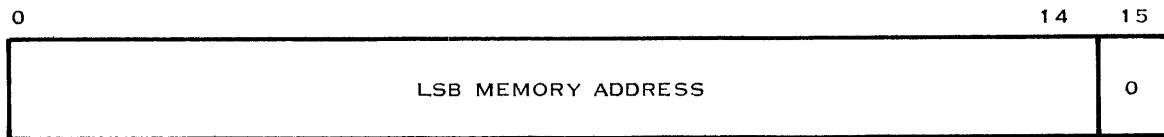

(A) 133997

Figure 3-7. Control Word 5

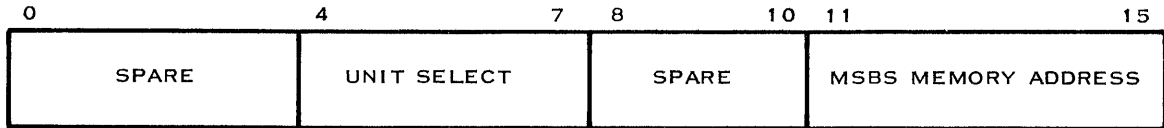

(A) 133998

Figure 3-8. Control Word 6

track. An attempt to transfer from a nonexistent TILINE memory results in a TILINE timeout status for the controller. For a write command, this field specifies the record word count.

3.5.6 LSB MEMORY ADDRESS, CONTROL WORD 5. The least significant bit (LSB) memory address is determined by control word 5 (Figure 3-7). By the use of this control word, the software selects the 15 least significant bits (LSB) of the TILINE memory address for the starting address of a data transfer. The controller fetches or stores data through the TILINE bus at sequential addresses until the word count decrements to zero. The CPU byte selection bit (bit 15) is ignored by the controller.

3.5.7 UNIT SELECT AND MSB MEMORY ADDRESS, CONTROL WORD 6. The disk drive selected and most significant bit (MSB) memory address are specified by control word 6 (Figure 3-8). Bits 0 through 3 and 8 through 11 of this field are not used.

Bits 4 through 7, Unit Select Field. The value of this field is used to select one of four disks (one fixed and one cartridge for each of two disk drives) attached to the disk controller. Only one disk drive can be selected at a time, as follows:

Bit 4 – Disk drive 0, fixed disk

Bit 5 – Disk drive 0, cartridge disk

Bit 6 – Disk drive 1, fixed disk

Bit 7 – Disk drive 1, cartridge disk.

Bits 11 through 15, MSB Memory Address. This field selects the five most significant bits of the TILINE memory address. These 5 bits are concatenated to the 15 LSB memory address bits of control word 5 to complete the 20-bit TILINE address.

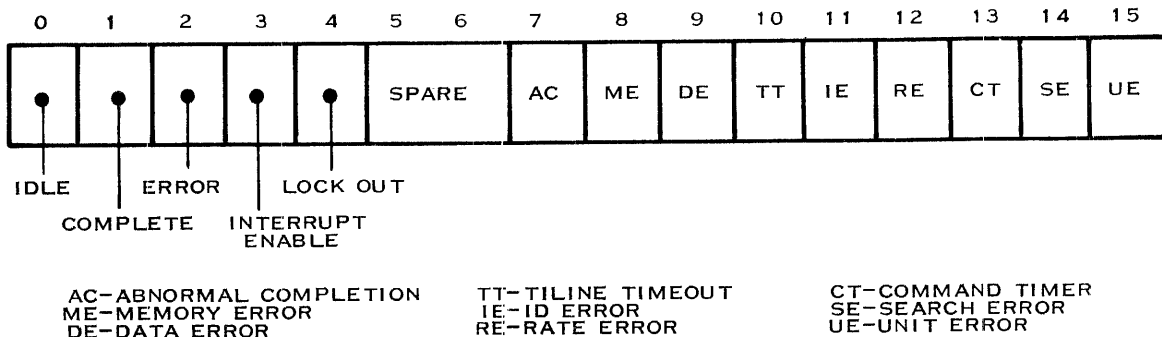

(A) 133999

Figure 3-9. Control Word 7

3.5.8 INTERRUPT AND CONTROLLER STATUS, CONTROL WORD 7. The interrupt and controller status field, shown in Figure 3-9, provides error information and controller status information to the TILINE bus. Bits 0 through 4 are used primarily to report controller completion and error information; bits 7 through 15 are used to convey the error status information about the controller. The individual bits and their functions are described as follows.

Bit 0, Idle. Bit 0 is logic zero when the controller is busy (performing a sequence, etc.). The software clears bit 0 to activate the disk controller to start execution of the command bits (bits 5 through 7) of control word 1. When a command is successfully completed or terminated because of an error condition, the disk controller sets bit 0 to logic 1. At the same time, the controller sets bit 1 of this field for a successful completion, or sets bit 2 if the operation is terminated as the result of an error condition.

Bit 1, Complete. Bit 1 is set when a command is completed without encountering an error. The bit may be reset by the software when servicing the interrupt.

Bit 2, Error. Bit 2 is set by the controller when an operation is terminated as the result of an error condition. This bit may be reset by software when servicing the interrupt or the status that was generated.

Bit 3, Interrupt. Bit 3 enables the controller interrupt when the complete bit (bit 1) or the error bit (bit 2) is set. This interrupt enable does not affect the unit attention interrupts which are controlled by the attention mask of control word 0.

Bit 4, Lockout. Bit 4 is set to logic 1 by the controller when control word 7 is read while the controller is idle. This bit is intended for use with multiprocessor systems.

Bits 5 and 6 are not used.

Bits 7 through 15, Controller Status. Bits 7 through 15 of control word 7 are controller status bits that represent the status of the controller after a command has been executed. The bits contain valid information when the error bit (bit 2) is set. A special case exists when a self-diagnostic error is detected. When a self-test error occurs, all error status bits of R7 (bits 7 through 15) are set.

Bit 7, Abnormal Completion Error (AC). Bit 7 is set if a disk operation is terminated because an I/O Reset, Power Failure Warning, or Master Power Reset was detected on the TILINE bus. (This bit is set when the disk is powered up.)



Bit 8, TILINE Memory Error (ME). This bit is set after completion of one of three disk commands: write data, write format, or unformatted write, when it has been determined that a memory error occurred during the time that data was being transferred from the TILINE bus to the disk controller. (This is normally a parity error.)

Bit 9, Data Error (DE). This bit is set during a disk read operation if any of the calculated check characters (cyclic redundancy characters or CRC) does not match the check character read from the disk data record(s). This means the CRC did not compare because of a parity error on the disk. All data transfer operations are terminated after a data error is encountered.

Bit 10, TILINE Timeout Error (TT). This bit is set if the controller addresses a nonexistent memory address or a slave fails to respond. TILINE timeout causes command termination. The timeout period is 10 ± 2 microseconds from the time master-device active (MDACT) is selected.

Bit 11, ID Word Error (IE). This bit is set when an ID word comparison error occurs during the ID verification of a read data or write data command. Verification includes comparison of ID words 1 and 2 and CRC checking of the three words. One hardware retry is attempted if an ID error occurs. If the retry fails, the command is aborted and error status is aborted.

Bit 12, Rate Error (RE). This bit is set when a timing error is encountered in the transfer of data between the TILINE master control and the disk interface:

1. During a read operation, the disk interface exceeds the capacity of the data buffer. The controller did not transfer the previous word across the TILINE before the next word is assembled with the buffer being full.
2. During a write operation, the disk interface empties the data buffer before completing the writing of a data sector.

Bit 13, Command Timer Timeout (CT). This bit is set when the 200 ± 20 millisecond command timer expires before an operation is completed. The timer acts as a dead-man timer which is reset when the controller reenters the IDLE loop.

Bit 14, Search Error (SE). Bit 14 is set when the controller does not detect a sync character (>6E) within one physical sector while attempting to read from the disk. Microcode attempts one retry before commanding abortion.

Bit 15, Unit Error (UE). The unit error status bit (bit 15) is set when an operation is terminated because of a disk drive error. The disk status register can be examined by software to determine the cause of the unit error. The following may cause a unit error:

- a. Unit not ready
- b. Unit off-line
- c. Unit unsafe
- d. Seek incomplete
- e. Write operation is attempted on write-protected unit.

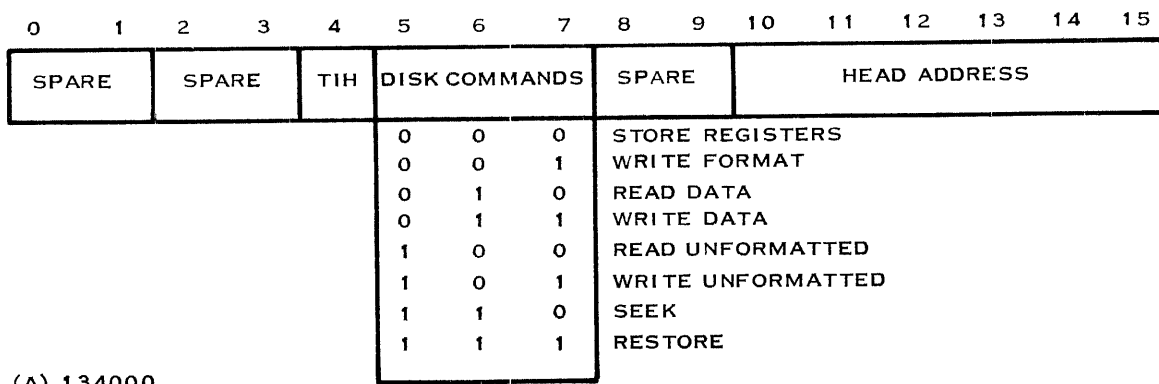

Figure 3-10. Command Format

3.5.9 DISK COMMANDS. As previously explained, disk commands are specified by bits 5, 6, and 7 of control word 1. The values of these bits provide the eight disk commands listed in Figure 3-10. These disk commands are described in the following paragraphs.

3.5.9.1 Store Registers Command. The store registers command causes the controller to store up to three words starting at the specified TILINE address. As shown in Figure 3-11, the three words contain the following information.

Word 1 – This word contains the total number of formatted words that can be recorded on a disk track. The number is $3840_{10} = 0F00_{16}$.

Word 2 – This word contains the sectors per track and the number of words of overhead per record parameters to be used in the calculations of the format parameters. Bits 8 through 15 of this word specify the overhead per record. This number is equal to $48_{10} = 30_{16}$ for the disk drive. Bits 0 through 7 of this word specify the number of sectors per track, which is $20_{10} = 14_{16}$.

Word 3 – This word contains the number of tracks per cylinder and the number of cylinders per disk, as follows:

Item	Bits	
Tracks/cylinder	0–4	$02_{10} = 02_{16}$
Cylinders/disk	5–15	$408_{10} = 198_{16}$
Composite	0–15	1198_{16}

An example of list words for a store registers command is given in Table 3-2.

3.5.9.2 Write Format Command. The write format command is used for formatting a new disk or for reformatting an existing disk. One complete track is formatted per command. An example of a write format command is given in Table 3-3.

After initialization, the controller checks for unit errors by examining the disk status (offline not ready, unsafe, write protect, seek incomplete): seeks to the specified cylinder; and sets the specified head address. The controller assembles the ID words from its internal registers and counters and records the word(s) on the disk at the specified disk track address as shown in Figure 3-12. The controller records the data field following the ID words with the data word in the specified TILINE address repeated for all data word positions.



Table 3-2. Example of List Words in a Store Registers Command

Word	Data	Comments
0	0000	Clears the disk status
1	0000	Command
2	0000	Not used
3	0000	Not used
4	0006	Three words
5	1000	Put three words into memory starting at TILINE address >00800
6	0800	Unit 0 ¹
7	0800	Set lockout. Reset idle and all status bits

Note:

¹ A unit does not have to be selected, but if no unit is selected, the disk status after the command is complete will have the not ready and off line status bits set.

Table 3-3. Write Format Command

Word	Data	Comments
0	0000	
1	0101	The command is bits 5 through 7; the surface address is = 1
2	0300	The record will be three sectors long. The sector address is zero (0000)
3	00CA	Cylinder address selected is >CA
4	03D8	Word count = Max. for 3 sectors/record
5	1000	Memory address
6	0800	Unit 0
7	1800	Use interrupts and leave lockout set

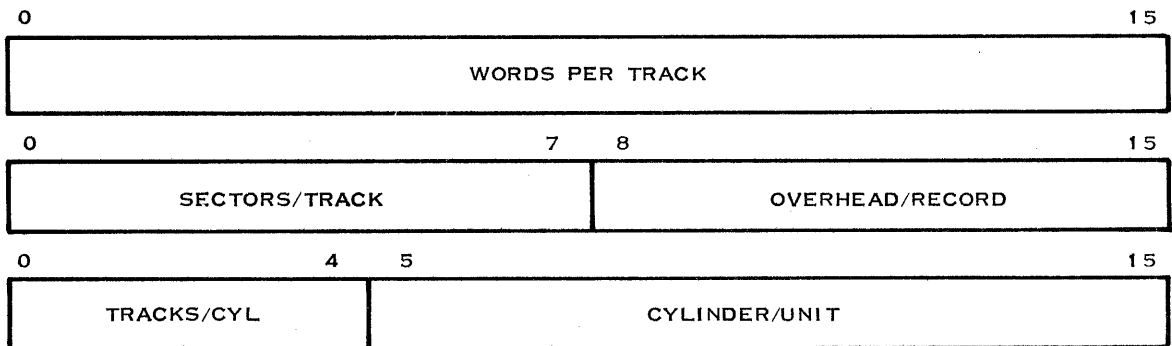

(A) 134001

Figure 3-11. Store Registers Data Format

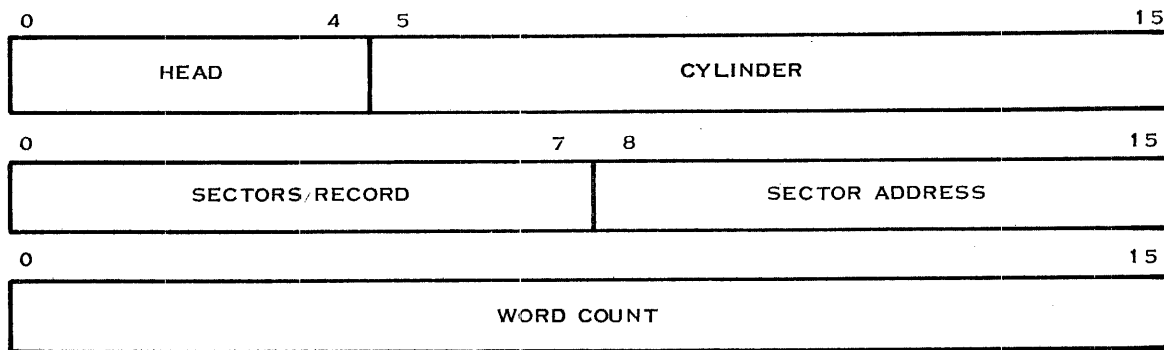

(A) 134002

Figure 3-12. Header Data Format

Table 3-4. Example of Read Data

Word	Data	Comments
0	0000	Clear the disk status
1	0200	Read surface 0
2	0300	3 sectors/record, start on sector 0
3	0000	Cylinder 0
4	2000	1000 words
5	0000	TILINE memory address = >F8000
6	021F	Unit 2
7	0	Do not use interrupts or lockout

Note:

In this example, the format of all of the tracks read must be 3 sectors per record or an error will be flagged.

The controller formats each record on the track with ID words, data, and the required gaps. Only the start of each record has the ID word written. When a record is longer than one sector, the controller writes across sector boundaries allowing more words to be packed into sectors than normally possible at one sector per record. The value of the record word count (ID word 3) is specified by control word 4.

3.5.9.3 Read Data Command. The read data command specifies the number of 16-bit words that will be transferred from the specified disk address to the specified TILINE address. An example of a read data command is given in Table 3-4.

After initialization, the controller checks for unit errors by examining disk status (offline, not ready, unsafe, seek incomplete); seeks to the specified cylinder; searches for the desired sector address; reads the ID words at that address; verifies the contents of ID words 1 and 2; stores the contents of ID word 3; verifies the CRC character of the ID words; waits the specified time; and looks for a sync character. After detecting the sync character, 16-bit words from the data field are assembled and transferred to the specified TILINE addresses (if transfer inhibit is not specified).



A failure to verify an ID word results in an ID error status (bit 11) and termination of the read data operation. When the controller encounters the end of a record but the remaining transfer word count is nonzero, the controller automatically continues reading data on the next sequential record of the track if it exists. The new record ID is checked before continuation of data gathering.

When the remaining transfer word count is zero but the controller has not encountered the end of a record, then the controller discontinues transmitting data words across the TILINE bus but continues to read data from the disk until the end-of-record is encountered so that the CRC character can be checked before loading status.

When the controller encounters the end of a track and the remaining transfer word count is nonzero, the controller automatically increments the head address to the next track; reads the ID words for the first sector (00) of that track; verifies the contents of ID words 1 and 2; stores the contents of ID word 3; verifies the CRC character following the ID words; looks for sync character and continues reading data from disk and again begins transferring data over the TILINE bus.

When the controller encounters the end of a cylinder, and the remaining transfer word count is nonzero, the controller automatically seeks to the next cylinder; selects head address zero for the new track; reads the ID words for sector 00; verifies the contents of ID words 1 and 2; stores the contents of ID word 3; verifies the CRC character following the ID words; looks for sync character and continues to read words from the disk and transfer them to the TILINE bus if transfer inhibit is not specified. If the end-of-cylinder occurs, and the remaining word count is nonzero, the operation will terminate with unit error and the resultant unit error will be seek incomplete caused by illegal address interlock ORed with seek incomplete.

3.5.9.4 Write Data Command. For a write data command the controller transfers the number of specified 16-bit words from the specified TILINE addresses to the specified disk addresses. After initialization, the controller checks for unit errors by examining disk status (offline, not ready, unsafe, write protect, seek incomplete); seeks to the specified cylinder; searches for the desired sector address; reads the ID words; verifies ID words 1 and 2; stores the contents of ID word 3; and verifies the CRC character following the ID words. If the ID words compare, the controller switches to the write mode and, after a specified delay, starts writing a sync character and data on the disk. If the ID words fail to compare, the operation is terminated with an ID status error.

Data is written on the disk until the specified number of words has been transferred unless a terminate condition is encountered. When the number of words to be transferred is greater than the number of words per record, the controller continues to the next sequential record. The next sequential record starts at the sector number whose value is equal to the beginning sector number of the last record plus the number of sectors per record.

When the transfer word count is less than the record word count, the controller fills the remainder of the record with zeros until the record word count has been decremented to zero.

The controller compares the ID words from its internal registers with the ID words read from disk at the specified sector address. If the ID words are identical, the CRC character is checked.



Table 3-5. Read Unformatted Command Example

Read Unformatted Command		
Word	Data	Comments
0	0000	
1	0400	Unformatted read
2	0001	Sector/record not used. Sector address = 1
3	0000	Cylinder 0
4	0008	4 ₁₀ words
5	1000	TILINE memory address = >00800
6	0400	Unit = 1
7	1800	Use interrupts and lockout

Data Received from Command		
Word	Data	Comments
0	0000	Track 0
1	0101	Sector/record = 1, sector = 1
2	0002	4 bytes, 2 words
3	5F5F	Cyclic Redundancy Character (CRC)

If the CRC character is of the proper value, the controller switches to the write mode and begins writing data. After the last data word of the sector is written, the controller records the CRC character that pertains to the data. ID words are not written for each sector on the disk, but are written only at the start of each record.

When the controller encounters the end of a track for a cylinder and the remaining transfer word count is nonzero, the controller automatically increments the head address to the next track; starts reading ID of sector zero; verifies the contents of ID words 1 and 2; stores the contents of ID word 3; verifies the CRC character following the ID words; and continues the write operation after the appropriate delay.

When the controller encounters the end of a cylinder, and the remaining transfer word count is nonzero, the controller automatically seeks to the next cylinder; selects head address zero for the new track; starts reading the ID for sector zero; verifies the ID words; and continues the write operation at sector zero.

3.5.9.5 Read Unformatted Command. Starting at the specified disk address, a read unformatted command transfers the specified number of 16-bit words from the disk to the specified TILINE addresses. The read unformatted command is used primarily for diagnostics and does not pay attention to sector boundaries and does not read IDs. An example of a read unformatted command and the data received from the command is given in Table 3-5.

After initialization, the controller checks for unit errors by examining disk status (offline, not ready, unsafe, seek incomplete); seeks to the proper cylinder; and starts transferring data to the TILINE after the sync of the specified sector address is detected. The controller continues to read all consecutive information, without regard to end-of-record or end-of-track boundaries, until the



specified number of words has been transferred or until a termination condition is encountered. A check for the CRC is performed at the end of the operation, and a data error status is reported if the CRC is not correct. This allows for error detection after the ID words if three words (six bytes) are specified in the word count.

3.5.9.6 Unformatted Write Command. An unformatted write command transfers the 16-bit words from the specified TILINE address to the specified disk address. Basically, the controller locates the proper sector and writes the specified bytes.

After initialization, the controller seeks to the specified cylinder and starts writing data on the disk after the sector mark of the specified sector address is detected and the correct lead gap has been generated. The controller continues to write all consecutive information, without regard to existing record boundaries, until the specified number of words has been transferred or until a termination condition is encountered. The controller adds a sync character to the beginning of the data and a CRC character at the end.

3.5.9.7 Seek Command. The seek command causes the disk controller to implement initialization and run a short diagnostic self-test. The command does not issue the new cylinder address to the disk drive. Instead, the command executes to termination and completes normally if no error conditions are detected. The actual seek is not performed because the heads for the fixed and removable disks move together as a unit on the same head carriage assembly. Independent seeks that would be issued in the overlapped mode between the two head assemblies are a physical impossibility. By issuing the command but not issuing it to the disk drive, the software command structure remains compatible with other disk systems.

If the interrupt mask is used to set an interrupt, the mask bit must not be set until after the command is issued. Otherwise, an interrupt occurs immediately. The interrupts are cleared by clearing the attention mask in the controller. Interrupts can also be set by setting the interrupt enable bit in R7. Upon completion, the controller sets an interrupt and holds it until the computer clears the interrupt enable bit in the controller. Table 3-6 is an example of a seek command.

3.5.9.8 Restore Command. The restore command is required if a seek incomplete disk status is detected by software or if an unsafe disk status occurs. The restore command positions the heads of the selected disk drive over cylinder zero.

Table 3-6. Example of a Seek Command

Word	Data	Comments
0	0000	
1	0600	Seek surface is not used
2	0000	Sector/record and sector and address are not used
3	0003	Cylinder = 3
4	0000	Word count is not used
5	0000	Memory address is not used
6	0100	Unit = 3
7	1800	Use controller interrupts and lockout



Before issuing the restore command, the offline status is checked. If the drive is offline, the restore command is aborted and the unit error status in R7 is set. If the drive is online, the restore command is issued to the drive and the controller executes a 0.5-second delay loop. Following the delay, the controller issues an interrupt to the computer if either the interrupt bit is set or one of the attention mask bits is set. Overlapped restores are not allowed between the fixed and cartridge disks because the heads are attached to the same carriage assembly and move together as a unit.

3.6 FORMATS AND DEFINITIONS

This paragraph gives the formats of the data written on the disk surfaces in a drive and a definition of hardware and firmware terms as related to software programming.

3.6.1 DEFINITION OF TERMS.

Disk Cartridge — A disk cartridge consists of one disk mounted on a hub. Refer to Figure 3-13.

Read/Write Heads — The four read/write heads (0 through 3) are mechanically locked to the carriage assembly and fly on an air boundary close to the recording surface, so the heads never actually contact the rotating disk surfaces in normal operation.

Disk Recording Surfaces — There are two data recording surfaces in a disk cartridge; the recording zone on each surface consists of a maximum of 408 cylinders.

Recording Tracks — A recording track consists of the recording area on a disk that includes the entire circumference of the cartridge. The track is subdivided by sector marks generated by the disk drive. Sector zero starts at the first sector mark that occurs after the time of the first index mark. The index signal is not used by the DS10 disk system.

Sectors are linked together to make records. Data is written continuously over sector boundaries for multiple sectors per record.

Data Word — A data word on the disk is 16 bits long. The number of data words in a record is selectable by the programmer up to a maximum number. To find the maximum number of words in one record, use the following formula:

$$\text{Max. words per record} = \frac{\text{Total words/track} - [(\text{Number records/track}) \times \text{overhead}]}{\text{Number records/track}}$$

See paragraph 3.5.9.1 for parameters.

Sector — Each track is divided into 20 sectors. The format of data recorded on a track consists of records of equal length which are separated by gaps. Gaps are automatically inserted by the controller to ensure reliable data recovery at each sector address over the range of operating temperatures and from recorded media exchanged between disk systems of the same type.

Record — The record size is variable but it must be one or more sectors, up to one track in length. The programmer can select the format of a track by setting the sectors/record parameter in bits 0 through 7 of command word 2. A sector mark defines the beginning of a physical record. Data is written across sector gaps if a record size greater than one is selected.

3.6.2 SECTOR FORMAT. A sector is a continuous recorded bit stream on a disk track which starts at a unique sector mark. A sector contains the fields shown in Figure 3-13. These fields are described in the following paragraphs.

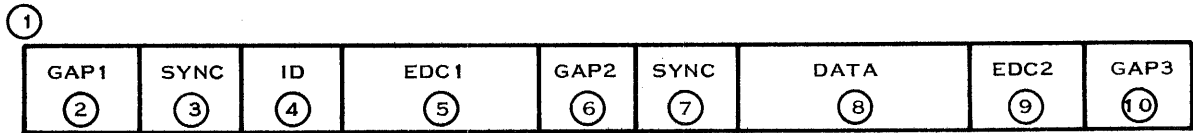

NOTE:

- ① A SECTOR MARK OCCURS AT THE BEGINNING OF EACH SECTOR.
- ② GAP 1 IS ALL ZEROS.
- ③ THE SYNC CHARACTER THAT BEGINS THE ID WORDS IS >6E.
- ④ THE THREE ID WORDS DEFINE:
 - A. TRACK ADDRESS
 - B. SECTORS PER RECORD AND SECTOR ADDRESS
 - C. RECORD WORD COUNT
- ⑤ THE ERROR DETECTION CODE (EDC) IS VERIFIED BY THE CRC GENERATED IN THE CONTROLLER.
- ⑥ GAP 2 IS AN INTER-RECORD GAP THAT IS USED TO SWITCH FROM READ TO WRITE MODE AFTER THE ID HAS BEEN VERIFIED. IT IS ALSO USED BY THE DISK TO LOCK IN ITS PLO.
- ⑦ THE SYNC CHARACTER IS USED TO DETECT THE BEGINNING OF THE VALID DATA STREAM. THE SYNC CHARACTER IS >6E.
- ⑧ THE DATA CONSISTS OF 16-BIT WORDS UP TO A MAXIMUM OF 144 WORDS (AT ONE SECTOR PER RECORD).
- ⑨ AN EDC CHECK IS PERFORMED AFTER THE DATA.
- ⑩ GAP 3 IS NOT WRITTEN ON AND IS USED TO PREVENT DATA LOSS DUE TO AN EARLY SECTOR MARK.

(A) 137262

Figure 3-13. Format of a Sector Record Bit Stream

3.6.2.1 Gap 1. This field of continuous logic zeros is used to compensate for late sector mark variations and to allow sufficient time for the data separator to lock in before the sync character is encountered. Gap 1 is 78 microseconds long.

3.6.2.2 Synchronization (Sync) Character. The disk controller uses the sync character to determine the start of intelligible data from the disk drive unit. After detecting sync, the bits in the data stream that follow the sync character are grouped into words for controller processing. The sync character is >6E (binary 0110 1110).

3.6.2.3 Identification (ID) Words. The three ID words are used by the disk controller to perform a check on the disk drive addressing when a read data or write data command is being executed. The ID words are written on the disk during a write format command. The ID words are then read and checked against the values that the controller has determined to be the proper values. If the ID words do not compare (ID words 1 and 2) or if a CRC is detected, the command aborts and no data is written on the disk if a write command has been issued. The ID check is made each time the controller moves to a new record. The ID words are formatted as follows:

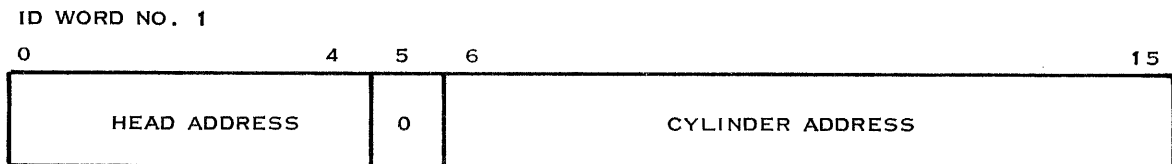

(A) 134007



ID Word Number 1 defines the track address. Bits 0 through 4 constitute the head address. Bit 5 is zero. Bits 6 through 15 constitute the cylinder address.

ID WORD NO. 2

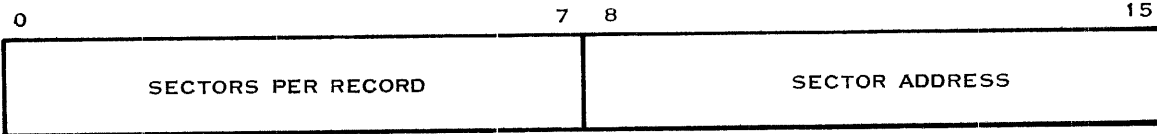

(A) 134008

ID Word Number 2 designates the number of sectors allocated per physical data record on this track. The sector address is the sector number within the track where this ID is recorded. This ID word denotes the sector where a record starts.

ID WORD NO. 3

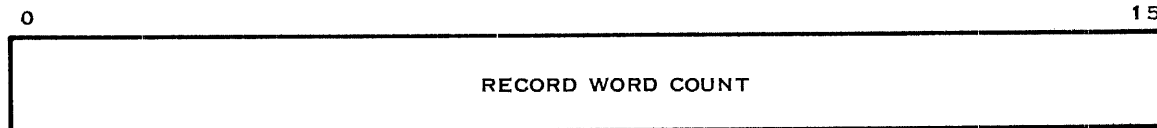

(A) 134009

ID Word Number 3 is the record word count that defines the size of the record which may include one or more sectors. All records on a track are the same length. The write format command ensures this condition by formatting one track per command. The word count of the ID word is stored in the controller to define the end of the data record during data transfers.

3.6.2.4 Error Detection Code (EDC) Number 1. This word is 16 bits of information generated by passing the three ID words through the CRC generator.

3.6.2.5 Gap 2. This is a gap used between ID words and data to switch to the write mode after the ID words have been verified. This gap is 35 microseconds long.

3.6.2.6 Data. The data field is a group of 16-bit words of information from the computer, up to a maximum of 144 words for each sector (formatted at one sector per record).

3.6.2.7 Error Detection Code (EDC) Number 2. This word is 16 bits of information generated by the controller by passing the data field through the CRC generator.

3.6.2.8 Gap 3. Gap 3 is a field where nothing is written, used to compensate for early sector mark variations. Gap 3 is also used to turn off write circuitry to the disk drive and do update calculations by the controller before the next record. Gap 3 is 157 microseconds long.



SECTION 4

OPERATION

4.1 GENERAL

This section describes the controls and indicators that are available to the operator for placing and keeping the Model DS10 Cartridge Disk System in a normal operating configuration.

4.2 CONTROLS AND INDICATORS

Figure 4-1 illustrates the locations of the controls and indicators on the disk drive. The following paragraphs describe the operations of those controls and indicators.

4.2.1 AC CIRCUIT BREAKER. The ac circuit breaker (labeled MAIN) located on the rear of the disk drive protects the disk drive power supply, spindle motor, and fan motor from damage due to overload conditions and provides main power switching for the disk drive. Normally, the circuit breaker is set to ON during installation and checkout of the disk drive, then left on for normal operation.

4.2.2 DC CIRCUIT BREAKER. The dc circuit breaker (labeled 34 VOLTS) located on the rear of the disk drive provides the logic circuitry with protection from overload due to circuit malfunctions. Normally, the breaker is set during installation and checkout of the disk drive, and left on for normal operations.

4.2.3 START/STOP SWITCH/INDICATOR. The START/STOP switch/indicator is an alternate action switch with a lighted pushbutton. If the indicator is not lighted and is operational, pressing the switch energizes the spindle motor and initiates the first seek mode, provided the following conditions exist:

- Circuit breakers closed
- Disk cartridge dust cover properly installed
- Cartridge hold-down arms properly positioned.

When the spindle motor is energized, the START/STOP indicator is lighted and remains lighted until the spindle motor stops in response to START/STOP switch operation.

Pressing the START/STOP switch while the indicator is lighted (spindle motor energized) de-energizes the spindle motor.

When the START/STOP switch is pressed to de-energize the spindle motor, the indicator remains lighted until the disk rotation has stopped and the interlock solenoids energize to release the disk cartridge.

NOTE

The first seek mode is automatic and requires approximately 65 seconds. The disk drive can be reset at any time after initiation of the start sequence. In the event of a potentially damaging fault during the first seek mode, the heads automatically retract and the disk drive stops.

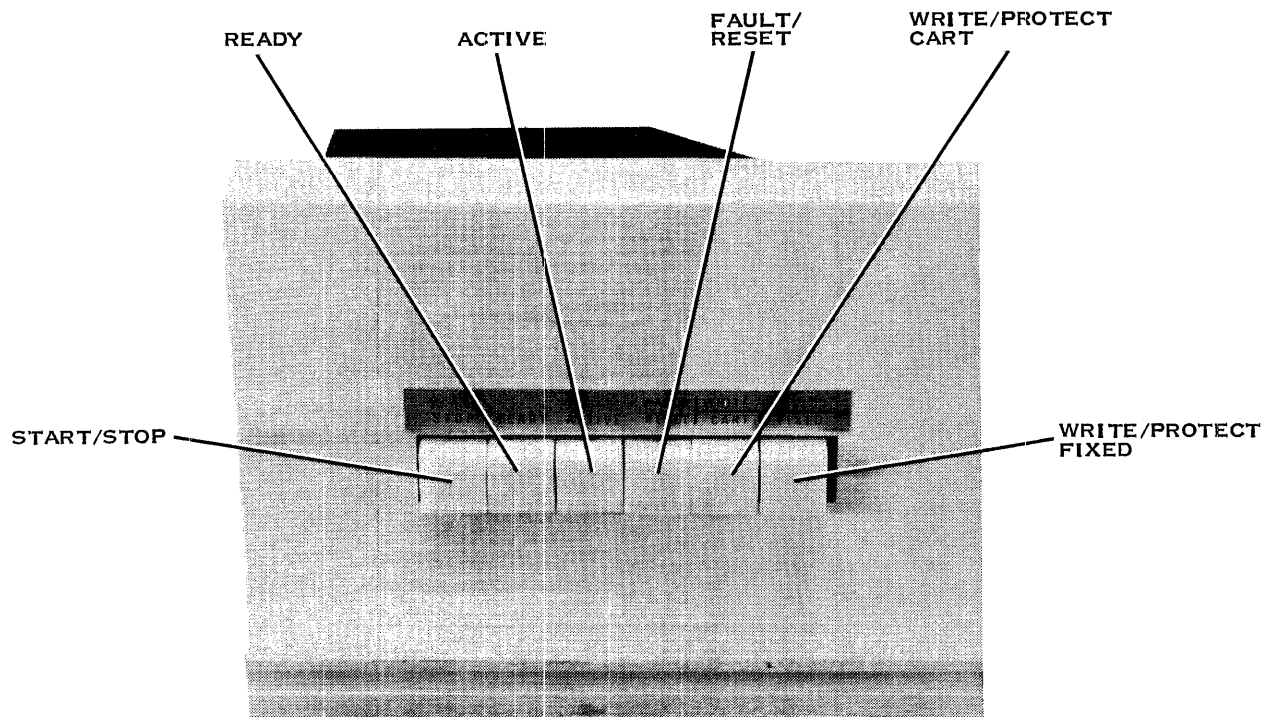

(A)137263A

Figure 4-1. Disk Drive Controls and Indicators

4.2.4 READY INDICATOR. The READY indicator is an indicator that is lighted when the spindle motor reaches operating speed, the heads are loaded, and the disk drive is ready for use. The READY indicator is extinguished during any fault, emergency retract, or stop operation.

4.2.5 ACTIVE INDICATOR. The ACTIVE indicator lights to indicate that the disk drive is actively engaged in any operation.

4.2.6 FAULT/RESET INDICATOR/SWITCH. The FAULT/RESET indicator/switch is lighted to indicate any fault except ac power failure. If a momentary ac power drop occurs, the heads automatically go into emergency retract and the disk drive stops. The disk drive automatically starts when ac power returns to normal.



The FAULT/RESET indicator lights to indicate the occurrence of a nondamaging fault, e.g. more than one head selected, simultaneous read and write instructions, etc. The FAULT/RESET indicator is extinguished by a return-to-zero-seek command (restore).

If a momentary nondamaging fault occurs, pressing the switch clears the fault logic and extinguishes the indicator. The FAULT/RESET switch cannot be used to clear a persistent fault.

4.2.7 WRITE/PROTECT CART INDICATOR/SWITCH. The WRITE/PROTECT CART indicator/switch is an alternate-action pushbutton switch with a lighted pushbutton. Pressing the switch when the indicator is not lighted inhibits writing and erasing of data on the cartridge disk and lights the indicator. When the indicator is lighted, the pushbutton remains partially depressed. Pressing the pushbutton with the indicator lighted removes the protect condition and extinguishes the indicator.

4.2.8 WRITE/PROTECT (FIXED) INDICATOR/SWITCH. The WRITE/PROTECT FIXED indicator/switch is an alternate-action pushbutton switch with a lighted pushbutton. Pressing the switch when the indicator is not lighted inhibits writing and erasing of data on the fixed disk and lights the indicator. When the indicator is lighted, the pushbutton remains partially depressed. Pressing the pushbutton with the indicator lighted removes the protect condition and extinguishes the indicator.

4.2.9 BRUSH INDICATOR. The BRUSH INDICATOR is a mechanical indicator/control that resembles a slotted head screw head. The position of the slot indicates whether or not the brushes that clean the disk are retracted. If the brushes are retracted, the slot in the indicator is aligned with the two black marks on either side of the hole. If the brushes do not retract when they are supposed to, a coin or screwdriver can be used to turn the BRUSH INDICATOR to retract the brushes *before attempting to remove the disk cartridge*.

4.3 OPERATING INSTRUCTIONS

The following paragraphs describe normal operating procedures for the disk system, including:

- Operating precautions
- Power application for online operation
- Disk cartridge installation and removal
- Write protect
- Stop and power removal
- Fault operating procedures
- Operator preventive maintenance procedures.

4.3.1 OPERATING PRECAUTIONS. The following precautions should be observed while operating the disk system.

- Keep cartridge access door (cabinet mount) closed or keep disk drive pushed into rack (rack mount) to prevent entry of atmospheric dust.
- If a pinging or scratching noise is heard (caused by head-to-disk contact), stop the disk drive by using the stop and power removal instructions in paragraph 4.3.5 and call the customer service engineer.

**NOTE**

Appropriate steps should be taken to safeguard data until the problem can be remedied. Such steps may include leaving the disk drive de-energized, replacing the disk cartridge with a scratch cartridge, and/or immediate transfer of the data on fixed disk.

- Follow disk cartridge installation and removal procedures in paragraph 4.3.3.
- Never attempt to override any interlock.

4.3.2 POWER APPLICATION FOR ONLINE OPERATION.**NOTE**

Steps 1, 2, 4, and 5 of this procedure are to be performed by maintenance personnel only.

1. Ensure that all system interconnection cables and power cables are properly connected and in good condition.
2. Verify that disk drive is properly configured for local ac line power.
3. Ensure that START/STOP switch/indicator is in STOP position (pushbutton raised and indicator extinguished).
4. Close dc circuit breaker.
5. Close ac circuit breaker and verify operation of blower motor.
6. Install disk cartridge in accordance with paragraph 4.3.3.
7. Press START/STOP switch/indicator. Ensure that pushbutton stays partially depressed and indicator lights.
8. Verify that FAULT indicator/switch remains extinguished.

NOTE

If FAULT indicator lights, perform fault operating procedure in paragraph 4.3.6.

9. Approximately 65 seconds after pressing START/STOP switch, READY indicator lights and disk drive is ready for operation initiated by computer.

4.3.3 DISK CARTRIDGE INSTALLATION AND REMOVAL. Disk cartridge installation and removal instructions are repeated here from Section 2 for convenience.**4.3.3.1 Disk Cartridge Installation.**

1. Raise cartridge access door (cabinet mount) or pull disk drive out of rack (rack mount).



NOTE

Power must be on and START/STOP lamp must be extinguished to release lock on hold-down arms.

Refer to Figure 2-43 for the remainder of this procedure.

2. Pull back hold-down arms.
3. Set disk cartridge upright on a firm supportive surface.
4. Hold disk cartridge cover release button to left while lifting cartridge handle to separate dust cover and disk.
5. Disengage dust cover from disk. Set cover aside.

CAUTION

Do not make abusive contact between disk and spindle. Ensure that the read/write heads are fully retracted and the brushes are completely out of the disk area. Remove any dust from magnetic chuck.

6. Position head opening of disk toward rear of disk drive and place disk onto spindle hub.
7. Rotate cartridge slowly back and forth until cartridge seats over spindle.
8. Turn handle down to seat cartridge.
9. Place dust cover (removed in step 5) open end down over cartridge.
10. Position hold-down arms over cartridge and dust cover.
11. Close cartridge access door (cabinet mount) or push disk drive into rack (rack mount).

4.3.3.2 Disk Cartridge Removal. Refer to Figure 2-43 for the following procedure.

1. Press START/STOP switch and wait for START/STOP indicator to be extinguished.

CAUTION

If START/STOP indicator is still illuminated after 2½ minutes and brushes are not fully retracted, contact customer service engineer.

2. Raise cartridge access door (cabinet mount) or pull disk drive out of rack (rack mount).
3. Pull back hold-down arms (arms will not move until cartridge rotation has stopped).
4. Remove cartridge dust cover.
5. Lift cartridge handle, hold cover release button to left, and lift cartridge up and out of disk drive by handle.



6. Place cartridge inside dust cover and fold down handle until a snap is heard indicating that the cartridge and dust cover are locked together.
7. Close cartridge access door (cabinet mount) or push disk drive back into rack (rack mount).

4.3.3.3 Removal of Disk Cartridge Following Power Failure or for Emergency. Removal of the disk cartridge following power failure or in an emergency situation should be performed only by the customer service engineer.

1. Wait approximately 3 minutes for cartridge to stop spinning.
2. Ensure that brush indicator is properly aligned.
3. Raise cartridge access cover (cabinet mount) or pull disk drive out of rack (rack mount).
4. Release pack locks by inserting a flat head screwdriver (or similar object) into hole on top of pack lock (See Figure 2-44). Press solenoid plunger into solenoid and tilt pack lock.
5. Pull back hold-down arms.
6. Remove cartridge dust cover.
7. Lift cartridge handle, hold cover release button to left, and lift cartridge up and out of disk drive by hand.
8. Place cartridge inside dust cover and fold down handle until a snap is heard indicating that the cartridge and dust cover are locked together.
9. Close cartridge access door (cabinet mount) or push disk drive back into rack (rack mount).

4.3.4 WRITE PROTECT. The operator initiates a write protect operation by pressing either the **WRITE/PROTECT CART** or **WRITE/PROTECT FIXED** switch and verifying that the appropriate indicator lights. The selected disk (cartridge or fixed) is then protected from writing and/or erasing.

4.3.5 STOP AND POWER REMOVAL. To stop the disk drive and remove power, observe the following sequence.

1. Press **START/STOP** switch and verify that the following happens:
 - a. **READY** indicator is extinguished.
 - b. **START** indicator is extinguished.
 - c. Spindle stops.
 - d. Pack locks open.



2. Remove disk cartridge, if desired, in accordance with instructions in paragraph 4.3.3.2.

NOTE

Step 3 must be performed by maintenance personnel only.

3. Set ac circuit breaker (labeled MAIN) on rear of disk drive to OFF.

4.3.6 CHANGING DISK ASSIGNMENTS. The fixed disk in the primary (or only) disk drive is normally designated disk 0, and the cartridge is designated disk 1. The corresponding designations for the secondary disk drive are disks 2 and 3. A jumper on the cable adapter board permits reversing the designations for a given disk drive.

The jumper plug is normally stored as shown in Figure 4-2. To reverse designations for disks 0 and 1, remove the jumper plug and insert it to connect J1 and J3. To reverse designations for disks 2 and 3, remove the jumper plug and insert it to connect J1 and J4.

4.3.7 FAULT OPERATING PROCEDURES. If the FAULT/RESET indicator lights during normal operation or power application, proceed as follows:

1. Press the FAULT/RESET switch. If the FAULT/RESET indicator is extinguished, normal operation can be continued. If it remains lighted, proceed to step 2.
2. Press the START/STOP switch and allow spindle to stop rotating.
3. Press the START/STOP switch and observe the FAULT/RESET indicator. If it is extinguished, normal operation can be resumed. If the FAULT indicator remains lighted, proceed to step 4.
4. Perform the stop and power removal procedure in paragraph 4.3.5.
5. Call a customer service engineer.

4.3.8 OPERATOR PREVENTIVE MAINTENANCE. Operator preventive maintenance is restricted to daily dusting of the outside of the cabinet (cabinet mount drive) or the front panel of the rack mount disk drive.

4.4 MAINTENANCE AIDS

Figure 4-3 shows the four light-emitting diodes (LEDs) on the disk controller (PWB version). Figure 4-4 shows the LEDs for the fine line PWB version of the disk controller. These four LEDs are visible when the cover is removed from the computer by maintenance personnel and provide the following information:

- **FAULT** — When lighted, the FAULT LED indicates that a microprogram type of failure has occurred and that the controller must be repaired. Specifically, the FAULT LED lights when the command timer on the controller times out, indicating that the controller-initiated operation was not completed within the prescribed 200 ± 20 milliseconds or a self-diagnostic failure occurred. The FAULT indicator is dimly lighted during normal operation. The indicator is lighted during self-test.
- **CLK** — Operation of the CLK LED is as follows:

LED not lighted — Disk controller clock not running. Possible TILINE access granted problem.

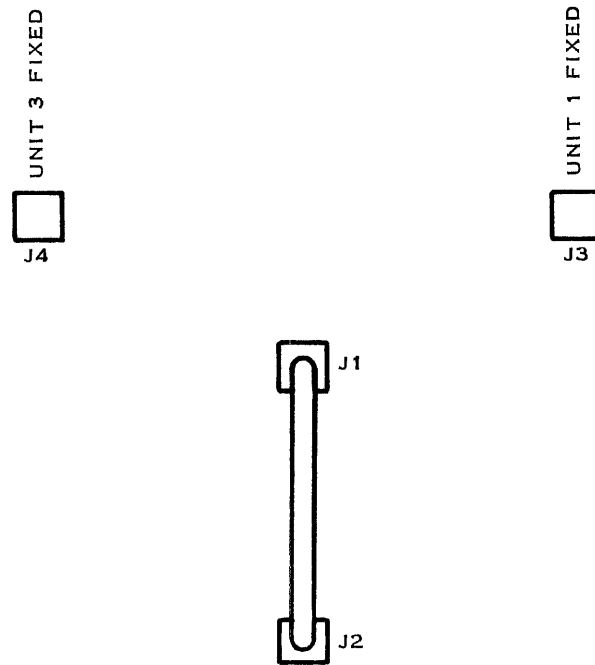

(A)137558A

Figure 4-2. Disk Designation Jumper

LED lighted but not bright – Clock running normally.

LED bright – Clock always on. Possible faulty clock circuit.

- **BUSY** — The **BUSY LED**, when lighted, indicates that the controller is servicing a TILINE I/O reset, or executing a command, a master power reset, or a power failure warning. When the **BUSY LED** is lighted, the controller cannot accept any commands.
- **INT** — The **INT LED** lights to indicate when the disk controller is issuing a TILINE interrupt.

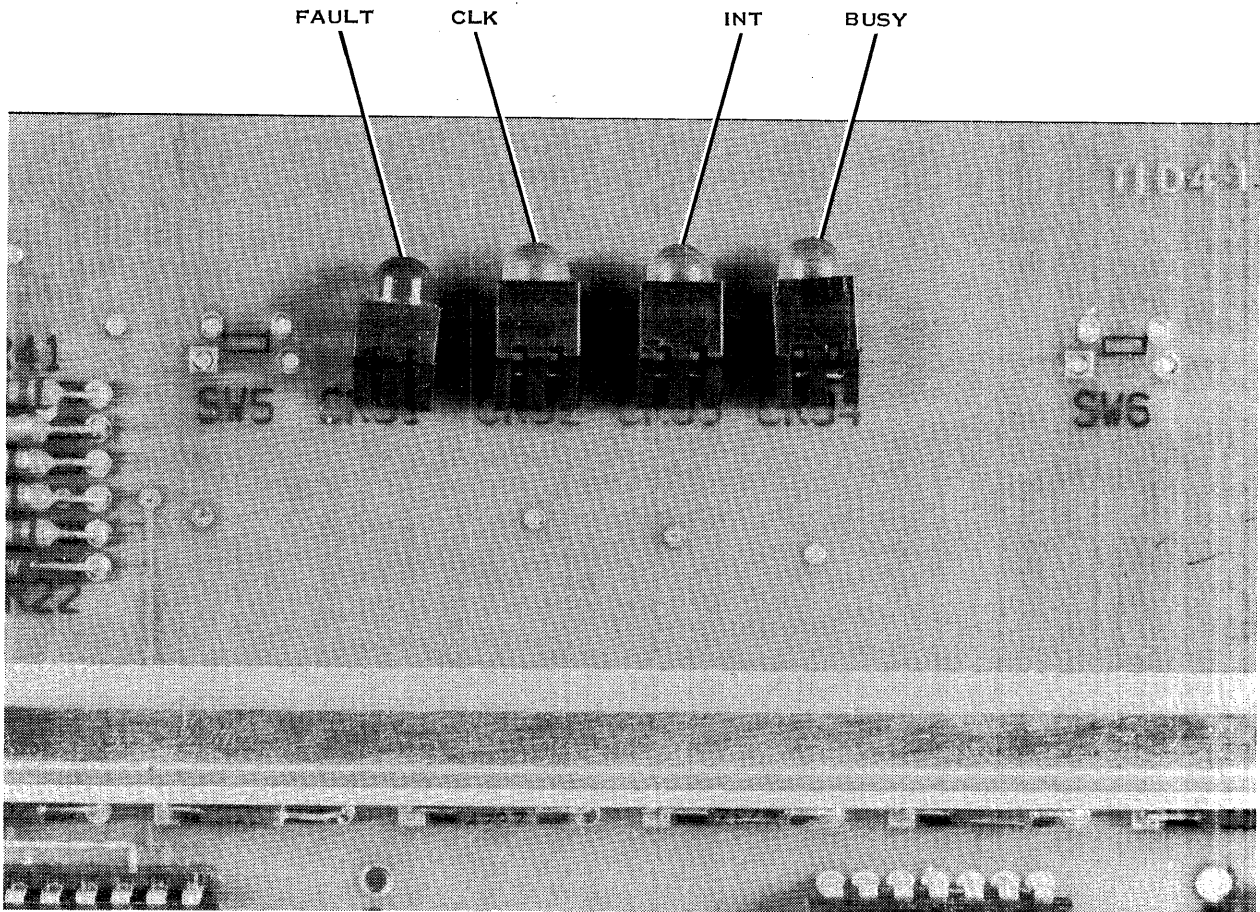

(A) 143673

Figure 4-3. Disk Controller LEDs (PWB Version)

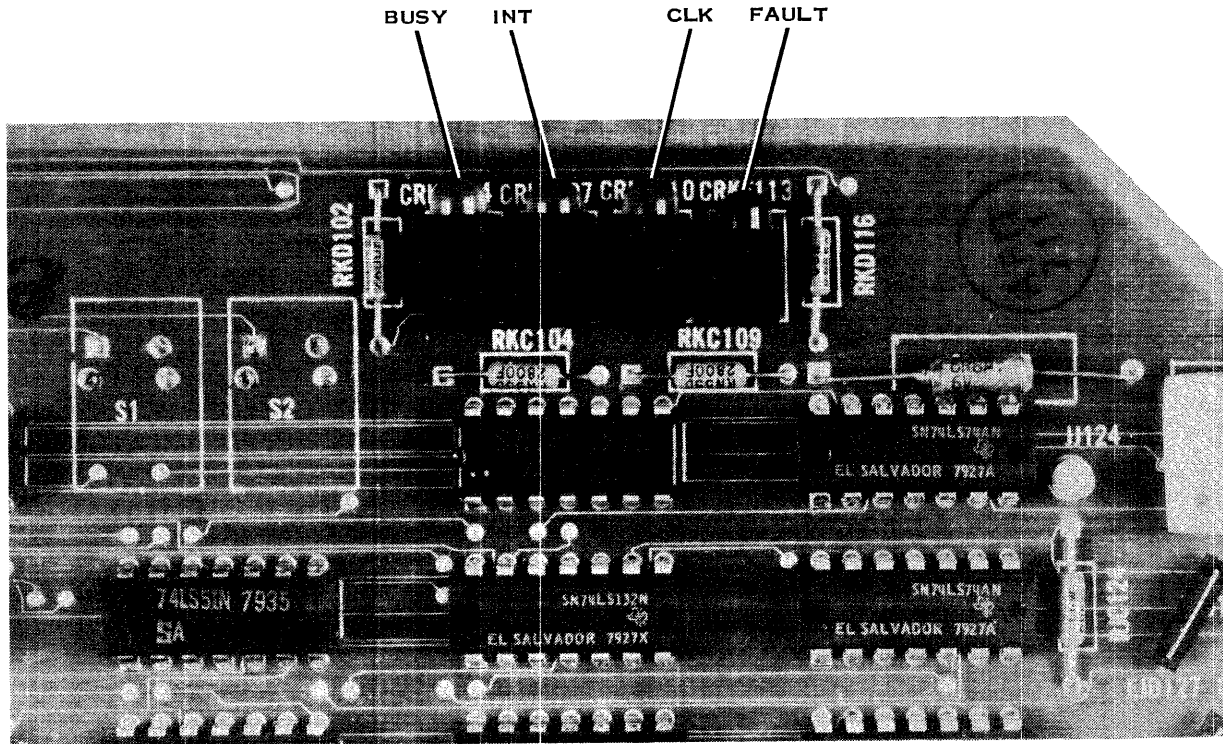

(A) 143667

Figure 4-4. Disk Controller LEDs (Fine Line PWB Version)



4.5 PREVENTIVE MAINTENANCE

Both the disk drive and the cartridge disk require preventive maintenance (PM) to ensure continued trouble-free performance. The following paragraphs explain the PM procedures for the rack mount disk drive, cabinet mount disk drive, and cartridge disk.

4.5.1 PREVENTIVE MAINTENANCE FOR THE RACK MOUNT DISK DRIVE. PM for the rack mount disk drive should be carried out at least once a month, and more often in dirty environments. To perform the necessary PM, follow these procedures:

1. Halt the disk drive and remove the cartridge disk by following the directions in paragraph 2.4.8.3.
2. Shut off the blower by moving the ac circuit breaker (located at the right rear of the disk drive, as viewed from the front) to OFF.
3. Remove the prefilter assembly (attached by a magnetic mount to the face of the disk drive). (The part number of the prefilter assembly kit is 0943848-0079.)
4. Take the filter element out of the prefilter assembly and wash it in hot water and detergent, rinse it, and dry it.
5. Replace the dry filter element in the prefilter assembly and reinstall the assembly on the disk drive.
6. Using a lint-free cloth lightly dampened with 93 percent isopropyl alcohol, wipe out the well for the cartridge disk.

CAUTION

Do not touch the heads while cleaning the well for the cartridge disk.

7. Power up the blower by moving the ac breaker to ON. Let the blower run 20 minutes to purge the air delivery system and provide thermal stabilization.
8. Resume normal operations.

4.5.2 PREVENTIVE MAINTENANCE FOR THE CABINET MOUNT DISK DRIVE. PM for the cabinet mount disk drive should also be carried out at least once a month, and more often in dirty environments. To perform the necessary PM, follow these procedures:

1. Halt the disk drive and remove the cartridge disk by following the directions in paragraph 2.4.8.3.
2. Shut off the blower by moving the ac circuit breaker (located at the right rear of the disk drive, as viewed from the front) to OFF.
3. Open the front of the cabinet by pulling out on the top edge of the front panel (to free the friction type latch). Remove the cabinet air filter (kit part number 943848-0049), which is horizontally installed under the front edge of the disk drive.
4. Wash the cabinet air filter in hot water and detergent, rinse it, and dry it. Replace the dry cabinet air filter in the disk drive.



5. Using a lint-free cloth, lightly dampened with 93 percent isopropyl alcohol, wipe out the well for the cartridge disk.

CAUTION

Do not touch the heads while cleaning the well for the cartridge disk.

6. Power up the blower by moving the ac breaker to ON. Let the blower run 20 minutes to purge the air delivery system and provide thermal stabilization.
7. Resume normal operations.

4.5.3 PREVENTIVE MAINTENANCE FOR THE CARTRIDGE DISK.

NOTE

Regular preventive maintenance (PM) procedures must be performed on cartridge disks every six months. The fixed disk, because of its sealed environment, does not require PM.

4.5.3.1 General. The cartridge disk is one of today's most advanced mass information storage systems. However, this seemingly ideal system requires special care to maintain optimum performance. Manufacturers originally considered disk packs and cartridge disks to be maintenance free. However, they have come to realize that regular cleaning and inspection are necessary to prevent costly system crashes, rerun time, and loss of valuable data. Regular PM is necessary on cartridge disks to alleviate costly problems that can arise to degrade the quality of data storage, render the cartridge disks unusable, or damage disk drives.

The need for PM arises in the following manner: Read/write heads fly over disk surfaces on an air bearing of 20 to 135 microinches, depending on the type of disk pack. Contamination in the form of dust, grease, metal filings, smoke particles, etc., build up on disk recording surfaces, decreasing the separation between read/write heads and disk surfaces (see Figure 4-5).

CAUTION

Damaged or questionable-quality cartridge disks must never be installed in a disk drive. Disk drives must not be used without a clean and serviceable air filter. To prevent damage to the cartridge disk, the filter must be checked at least twice a year, and monthly in dusty or nontemperature-controlled locations.

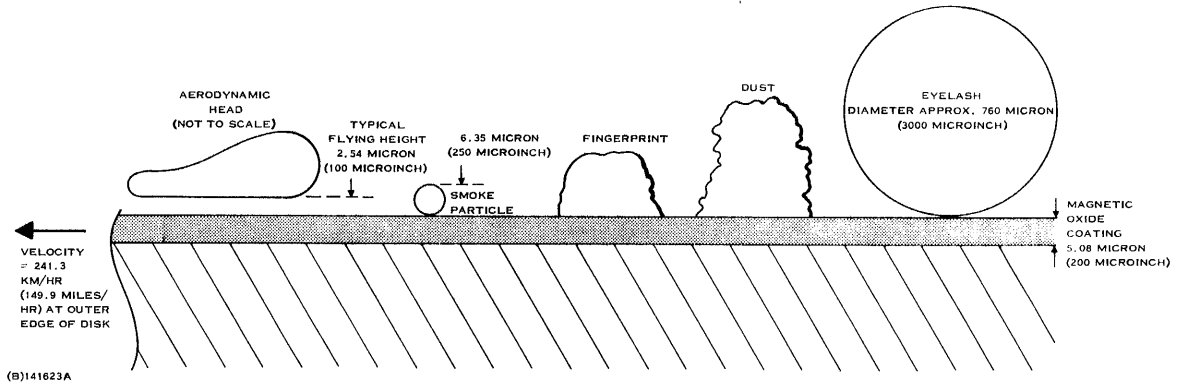

Figure 4-5. Disk Contaminants

Disk contaminants cause temporary errors, retries, and data checks. At this stage, most data should be recoverable by thorough cleaning of the disk surfaces. If foreign particles are allowed to build up, head crashes and other permanent damage to heads and disk surfaces are inevitable.

4.5.3.2 Maintenance Procedures. For these reasons, all cartridge disks should be removed from service and PM performed by a qualified vendor or manufacturer every six months. Contact your local TI sales and service office for help in locating a qualified vendor convenient to you. Normally the PM is performed at the customer's location. Be sure to call in advance to schedule the PM.

During PM procedures, the vendor should clean and inspect the following areas in the cartridge disk:

- Top and bottom for cracks, chips, dirt, wear
- Spindle retainer for condition and wear
- Trim shield retaining screws for condition and tightness
- Spindle lock for wear, dirt, binding
- Thrust bearing, races, washers for damage and wear
- Hub and cone area for dirt, film, nicks, burrs
- Index (bottom protective) disk for bends, damage, axial runout
- Recording disks for surface damage and axial runout.

The vendor performing PM on the cartridge disks will indicate the status of each disk cleaned and inspected. This will detail whether the disk is good, requires repair, or is nonrepairable. Many problems can be corrected by cleaning, but if a disk is found to be damaged, it *must not* be used again and should be scrapped or repaired before returning to service. Replacing cartridge disks can be costly, but quite inexpensive compared to system downtime due to a disk drive crash or loss of data on a disk. Some disks may be repairable, in which case the repairs are usually done at the PM vendor's office.



ALPHABETICAL INDEX

INTRODUCTION

HOW TO USE THE INDEX

The index, table of contents, list of illustrations, and list of tables are used in conjunction to obtain the location of the desired subject. Once the subject or topic has been located in the index, use the appropriate paragraph number, figure number, or table number to obtain the corresponding page number from the table of contents, list of illustrations, or list of tables. The table of contents does not contain four-level paragraph entries. Therefore, for four-level paragraph numbers such as 2.3.1.2, use the three-level number and the corresponding page number. In this case, the three-level number is 2.3.1.

INDEX ENTRIES

The following index lists key words and concepts from the subject material of the manual together with the area(s) in the manual that supply major coverage of the listed concept. The numbers along the right side of the listing reference the following manual areas:

- Sections - References to Sections of the manual appear as “Section x” with the symbol x representing any numeric quantity.
- Appendixes - References to Appendixes of the manual appear as “Appendix y” with the symbol y representing any capital letter.
- Paragraphs - References to paragraphs of the manual appear as a series of alphanumeric or numeric characters punctuated with decimal points. Only the first character of the string may be a letter; all subsequent characters are numbers. The first character refers to the section or appendix of the manual in which the paragraph is found.
- Tables - References to tables in the manual are represented by the capital letter T followed immediately by another alphanumeric character (representing the section or appendix of the manual containing the table). The second character is followed by a dash (-) and a number:

Tx-yy

- Figures - References to figures in the manual are represented by the capital letter F followed immediately by another alphanumeric character (representing the section or appendix of the manual containing the figure). The second character is followed by a dash (-) and a number:

Fx-yy

- Other entries in the Index - References to other entries in the index are preceded by the word “See” followed by the referenced entry.

The index is divided into sections for the letters of the alphabet. Acronyms and mnemonics (words made up entirely of capital letters) are listed first within each section. Words that begin with a capital letter follow the acronyms and mnemonics.



Abnormal Completion Bit 3.5.8, F3-1, F3-9
 Ac Circuit Breaker 4.2.1
 Ac Power Requirements, Disk Drive . . 2.2.3, T1-3
 Access:
 Granted (6- and 13-Slot Chassis) 2.4.3.1
 Granted (17-Slot Chassis) 2.4.3.2
 Jumpers 2.4.3.1, 2.4.3.2, F2-22,
 F2-23, F2-24, F2-25, F2-26
 Time T1-1
 Accessories, Unpacking 2.3.4
 ACTIVE Indicator 4.2.5, F4-1
 Adapter, Cable 2.4.6, F2-35, T2-1
 Address:
 Cylinder 3.5.4, 3.6.2.3, F3-1, F3-5,
 Head 3.6.2.3, F3-1,
 Head/Surface 3.5.2, F3-3
 LSB Memory 3.5.6, F3-1, F3-7
 Memory F3-1
 MSB Memory 3.5.7, F3-1, F3-8
 Sector 3.5.3, 3.6.2.3, F3-1, F3-4
 Starting F3-1, F3-4
 Selection 2.4.4.1, F2-32, T2-4
 Slave, Disk Controller 1.2.2
 Switches, TILINE 2.1, F2-25, F2-26, F2-32
 Addressing 1.3, 3.2, F3-1
 Altitude, Operating T2-2
 Assembly, Rack Slide F2-20
 Attention Interrupt Mask Bits 3.5.1, F3-2

 Bit Assignments F3-1
 Block Diagram F1-2, F1-5
 BRUSH INDICATOR 4.2.9, F2-42
 Busy 3.3
 LED 4.4, F4-3, F4-4

 Cabinet Mount Disk Drive 1.2.3, 2.2.2, 2.3.3
 2.4.2, 4.5.2, F1-8, F1-10, F2-3, F2-5, T2-1
 Physical Dimensions F1-10, F2-3
 Unpacking Instructions 2.3.3
 Cable:
 Adapter 2.4.6, F2-35, T2-1
 Connectors F2-33
 Cables 2.2.6, 2.4.6, F2-1, T2-1
 Cabling 1.2, 2.4.6, F1-5, F2-33, F2-34
 Restrictions 2.2.6
 Capacity, Storage 1.2.3, T1-1
 Card Cage F2-9
 Carriage Lock Pin 2.3.1, F2-8
 Cartridge Locks 2.4.8.4, F2-44
 Characteristics:
 Electrical 1.4, T1-2
 Physical 1.4, T1-2
 Checkout, Operational 2.5
 Circuit Breaker:
 Ac 4.2.1
 Dc 4.2.2
 Circuit Breakers F2-41
 CLK LED 4.4, F4-3, F4-4
 Command:
 Completion 3.4, 3.4.1, 3.4.2
 Interrupts 3.4.2.1
 Control 3.3, 3.5.2
 Read Data 3.5.2, 3.5.9.3, F3-1, F3-3,
 F3-10, T3-1, T3-4
 Read Unformatted . . 3.5.9.5, F3-1, F3-10, T3-5

Restore . . 3.5.2, 3.5.9.8, F3-1, F3-3, F3-10, T3-1
 Seek 3.5.2, 3.5.9.7, F3-1, F3-3, F3-10,
 T3-1, T3-6
 Store Registers 3.5.2, 3.5.9.1, F3-1, F3-3,
 F3-10, F3-11, T3-1, T3-2
 Timer Bit 3.5.8, F3-1, F3-9
 Unformatted Read . . 3.5.2, 3.5.9.5, F3-3, T3-1
 Unformatted Write . . 3.5.2, 3.5.9.6, F3-1, F3-3,
 F3-10, T3-1
 Write Data 3.5.2, 3.5.9.4, F3-3, F3-10,
 T3-1, T3-4
 Write Format 3.5.2, 3.5.9.2, F3-1, F3-3,
 F3-10, T3-1, T3-3

 Commands F3-1
 Disk 3.5.2, 3.5.9, F3-1, F3-3, F3-10
 Compatibility, Disk Controller 3.4
 Complete Bit 3.5.8, F3-1, F3-9
 Component Location 1.2.3, F1-2
 Components F1-1, F1-2, F1-5, F2-1, T2-1
 Computer:
 Chassis Preparation 2.4.3, 2.4.3.1, 2.4.3.2
 Configuration 1.2, 2.1, F1-2, F1-5, F2-1
 Control:
 PWB Switch Settings F2-11
 Word Formats 3.5, F3-1
 Words 3.3, 3.5, F3-1
 Controller:
 Busy F3-1
 Slave Address 1.2.2
 Status:
 Bits 3.5.8, F3-9
 Word F3-1
 Controls 4.2, F4-1
 Controls and Indicators 4.2, F4-1
 Cylinder Address 3.5.4, 3.6.2.3, F3-1, F3-5
 Cylinders Per Disk Drive . . . 3.5.9.1, F3-1, F3-11,
 T1-1

 Data 3.6.2.6
 Error Bit 3.5.8, F3-1, F3-9
 Recovery PWB Switch Settings F2-14
 Transfer 1.1, 1.2.1, 1.2.2, 1.3, F1-2
 Rate 1.1
 Dc Circuit Breaker 4.2.2
 Definitions 3.6
 Density:
 Recording T1-1
 Storage 1.1
 Track T1-1
 Dimensions, Rack F2-2
 Disk:
 Assignments 4.3.6, F4-2
 Cartridge 2.3.5, 3.6.1, F2-18, F2-43, T2-1
 Handling Instructions 2.3.5.2
 Installation 2.4.8, 2.4.8.2, 4.3.3,
 4.3.3.1, F2-43
 Removal 2.4.8, 2.4.8.3,
 4.3.3, 4.3.3.2, 4.3.3.3
 Storage Instructions 2.3.5, 2.3.5.3
 Unpacking Instructions 2.3.5, 2.3.5.3
 Commands 3.5.2, 3.5.9, F3-1, F3-3, F3-10
 Contaminants 4.5.3.1, F4-5
 Controller 1.1, 1.2.2, 2.4.4, F1-1, F1-2,
 F1-5, F1-6, F1-7, F2-1, F2-31, T2-1



Compatibility 3.4
Installation 2.4.5
Jumpers F2-17
LEDs 4.4, F4-3, F4-4
Operations 1.2.2
Physical Dimensions F2-2, F2-3, T1-2
Power Requirements T1-2
Preparation 2.4.4
Programming 3.2
Shipping Configuration F2-16
Unpacking Instructions 2.3.2
Designation Jumper 4.3.6, F4-2

Drive:

Air Filtering System, Purging 2.4.8.1
I/O Board F2-37, F2-38, F2-39, F2-40
Physical Dimensions F1-9, F1-10, F2-2, F2-3, T1-2
Power Requirements 2.2.3, T1-2, T1-3
PWB Locations F2-10
Specifications T1-1
Start Current T1-3
Medium 1.2.3
Recording Surfaces 3.6.1
Speed 1.2.3
Status 3.5.1, F3-2
Word F3-1
System Components F1-1, F1-2, F1-5, T2-1
See also Cabinet Mount, Rack Mount
Dust Cover F2-43

Electrical Characteristics 1.4, T1-2
Emergency 2.4.8.4, 4.3.3.3
End-of-Cylinder Bit F3-1
Environment 2.2.5
Environmental Requirements T2-2

Error:

Bit 3.5.8, F3-1, F3-9
Detection Code:
(EDC) Number 1 3.6.2.4
(EDC) Number 2 3.6.2.7
Detection Codes 3.6.2.4, 3.6.2.7
Even Byte Count 3.5.5, F3-1, F3-6
Expansion 2.1

FAULT/RESET:

Indicator 4.2.6, F4-1
LED 4.4, F4-3, F4-4
Switch 4.2.6, F4-1
Fault Operating Procedures 4.3.7

Format:

Header F3-1
Data F3-12
Sector 3.6.2
Store Registers Data F3-1

Formats 3.6
Control Word 3.5, F3-1

Gap:

1 3.6.2.1
2 3.6.2.5
3 3.6.2.8
General Description Section 1

Head Address 3.6.2.3, F3-1, F3-10
Head/Surface Address 3.5.2, F3-3
Header:
Data Format F3-12
Format F3-1

Heads:
per Cylinder T1-1
per Drive T1-1
Read/Write 3.6.1
Humidity T1-2
Operating T2-2

ID 3.6.2.3
Error Bit 3.5.8, F3-1, F3-9
Words 2.6.2.3
Idle Bit 3.5.8, F3-1, F3-9

Indicator:

ACTIVE 4.2.5, F4-1
BRUSH 4.2.9, F2-42
FAULT/RESET 4.2.6, F4-1
READY 4.2.4, F4-1
START/STOP 4.2.3, F4-1
WRITE/PROTECT CART 4.2.7, F4-1
WRITE/PROTECT FIXED 4.2.8, F4-1

Indicators 4.2, F4-1
Installation Section 2
Disk Controller 2.4.5
Instructions 2.4
Cabinet Mount Disk Drive 2.4.2
Rack Mount Disk Drive 2.4.1
Instructions, Operating 4.3
INT LED 4.4, F4-3, F4-4
Interfaces F1-2

Interrupt:

Connections 2.4.3.2, 2.4.3.4, F2-25, F2-27, F2-28, F2-29
Enable Bit 3.5.8, F3-1, F3-9
Level Assignments 2.1
Restore Completion 3.4.2.2
Seek 3.4.2.2
Interrupts 3.4, 3.4.2.1
Command Completion 3.4.2.1

Jumper, Disk Designation 4.3.6, F4-2

Jumpers:

Access Granted 2.4.3.1, 2.4.3.2, F2-22, F2-23, F2-24, F2-25, F2-26
Disk Controller F2-17
Voltage F2-19

Latency Time T1-1
Lockout Bit 3.5.8, F3-1, F3-9
LSB Memory Address 3.5.6, F3-1, F3-7
Maintenance:
Aids 4.4, F4-3
Preventive 4.3.8, 4.5

Memory:
Address:
LSB 3.5.6, F3-1, F3-7
MSB 3.5.7, F3-1, F3-8
Error Bit 3.5.8, F3-1, F3-9
MSB Memory Address 3.5.7, F3-1, F3-8



Not Ready Bit 3.5.1, F3-1, F3-2

Offline Bit 3.5.1, F3-1, F3-2

Operating:

- Altitude T2-2
- Humidity T2-2
- Instructions 4.3
- Precaution 4.3.1
- Temperature T2-2

Operation Section 4

Operational Checkout 2.5

Operating System 2.2.4

Operator Preventive Maintenance 4.3.8

Options 2.1

- Voltage T2-3

Overhead T1-1

- per Record 3.5.9.1, F3-1, F3-11

Parity Error 1.2.1

Physical:

- Characteristics 1.4, T1-2
- Dimensions:

 - Controller T1-2
 - Disk Drive F1-9, F1-10, F2-2, F2-3, T1-2

Positional Priority 1.2.2, 2.4.3.1

Power:

- Application 4.3.2
- Failure 2.4.8.4, 4.3.3.3
- Removal 4.3.5
- Requirements:

 - Disk Controller T1-2
 - Disk Drive 2.2.3, T1-2

Precautions, Operating 4.3.1

Preventive Maintenance 4.3.8, 4.5

- for Cabinet Mount Disk Drive 4.5.2
- for Rack Mount Disk Drive 4.5.1
- for the Cartridge Disk 4.5.3

Priority 1.2.2, 2.4.3.1

Programming Section 3

- Disk Controller 3.2

PWB Locations Disk Drive F2-10

Rack Dimensions F2-2

Rack Mount Disk Drive 1.2.3, 2.2.1, 2.3.1, 2.4.1, 4.5.1, F1-1, F2-1, F2-2, F2-4, F2-6, F2-7, T2-1

- Physical Dimensions F1-9, F2-2
- Unpacking Instructions 2.3.1

Rack Slide Assembly Mounting F2-20

Rate Error Bit 3.5.8, F3-1, F3-9

Read:

- Cycle Timing F1-4
- Data Command 3.5.2, 3.5.9.3, F3-1, F3-3, F3-10, T3-1, T3-4
- Unformatted Command 3.5.9.5, F3-1, F3-10, T3-5

Read/Write Heads 3.6.1

READY Indicator 4.2.4, F4-1

Record 3.6.1

- Word Count 3.6.2.3

Recording:

- Density T1-1
- Mode T1-1
- Surfaces 3.6.1
- per Drive T1-1
- Tracks 3.6.1

Restore Command 3.5.2, 3.5.9.8, F3-1, F3-3, F3-10, T3-1

R/W/E PWB Switch Settings F2-15

Search Error Bit 3.5.8, F3-1, F3-9

Sector 3.6.1

- Address 3.5.3, 3.6.2.3, F3-1, F3-4
- Format 3.6.2
- PWB Switch Settings F2-12
- Starting Address F3-1, F3-4

Sectors:

- per Drive T1-1
- Record 3.5.3, 3.6.2.3, F3-1, F3-4
- Track 3.5.9.1, F3-1, F3-11, T1-1

Seek:

- Command 3.5.2, 3.5.9.7, F3-1, F3-3, F3-10, T3-1, T3-6
- Incomplete Bit 3.5.1, F3-1, F3-2
- Interrupt 3.4.2.2

Servo PWB Switch Settings F2-13

Shipping Configuration:

- Cabinet Mount Disk Drive F2-5
- Rack Mount Disk Drive F2-4

Site Requirements 2.2, T2-2

Slave Address, Controller 1.2.2

Specifications, Disk Drive T1-1

Speed, Spindle T1-1

Start Current, Disk Drive T1-3

START/STOP:

- Indicator 4.2.3, F4-1
- Switch 4.2.3, F4-1

Status Word, Controller F3-1

Stop 4.3.5

Storage:

- Capacity 1.2.3, T1-1
- Density 1.1

Store Registers:

- Command 3.5.2, 3.5.9.1, F3-1, F3-3, F3-10, F3-11, T3-1, T3-2
- Data Format F3-1

Switch:

- FAULT/RESET 4.2.6, F4-1
- Settings:

 - Control PWB F2-11
 - Data Recovery PWB F2-14
 - R/W/E PWB F2-15
 - Sector PWB F2-12
 - Servo PWB F2-13
 - START/STOP 4.2.3, F4-1
 - WRITE/PROTECT CART 4.2.7, F4-1
 - WRITE/PROTECT FIXED 4.2.8, F4-1

Sync 3.6.2.2

System:

- Configuration 1.2, F1-2, F1-5
- Operation 1.3
- Specifications 1.4

Temperature T1-2, T2-2

TILINE:

- Address 1.2.1, 2.1
- Selection 2.4.4.1, F2-32, T2-4



Bus	1.2.1, F1-2	Select	F3-1
Controller Operation	1.2.1	Field	3.5.7, F3-8
Data (TLDAT, 00-15)	1.2.1	Unpacking Instructions	2.3, 2.3.1, 2.3.4
Go (TLGO-)	1.2.1	Cabinet Mount Disk Drive	2.3.3
Master-to-Slave:		Disk Controller	2.3.2
Read Cycle Timing	F1-4	Rack Mount Disk Drive	2.3.1
Write Cycle Timing	F1-3	Unsafe Bit	3.5.1, F3-1, F3-2
Memory Error (TLMER-)	1.2.1		
Operation	1.2.2	Voltage:	
Read (TLREAD)	1.2.1	Conversion	2.3.6, F2-19, T2-3
Slave Address Switches	F2-32, T2-4	Jumpers	F2-19
Terminate (TLTM-)	1.2.1, 3.3	Options	T2-3
Timeout Bit	3.5.8, F3-1, F3-9	Transients	2.1
Timing:		Word Count	3.5.5, F3-1, F3-6
Read Cycle	F1-4	Words Per Track	3.5.9.1, F3-1, F3-11
Write Cycle	F1-3	Write:	
TLADR (00-19)	1.2.1, F1-3, F1-4	Cycle Timing	F1-3
TLDAT, 00-15	1.2.1, F1-3, F1-4	Data Command	3.5.2, 3.5.9.4, F3-1, F3-3,
TLGO-	1.2.1, F1-3, F1-4	F3-10, T3-1, T3-4	
TLMER-	1.2.1, F1-3, F1-4	Format Command	3.5.2, 3.5.9.2, F3-1,
TLREAD	1.2.1, F1-3, F1-4	F3-3, F3-10, T3-1, T3-3	
TLTM-	1.2.1, 3.3, F1-3, F1-4	Protect	4.3.4
Track Density	T1-1	Bit	3.5.1, F3-1, F3-2
Tracks:		Unformatted Command	3.5.2, 3.5.9.6
per Cylinder	3.5.9.1, F3-1, F3-10, T1-1	F3-1, F3-3, F3-10, T3-1	
per Drive	T1-1	WRITE/PROTECT CART:	
Recording	3.6.1	Indicator	4.2.7, F4-1
Transfer Inhibit Bit	3.5.2, F3-1, F3-3	Switch	4.2.7, F4-1
Unformat Read Command	3.5.2, 3.5.9.5,	WRITE/PROTECT FIXED:	
F3-1, F3-3, F3-10, T3-1, T3-5		Indicator	4.2.8, F4-1
Unformat Write Command	3.5.2, 3.5.9.6,	Switch	4.2.8, F4-1
F3-3, F3-10, T3-1			
Unit:			
Error Bit	3.5.8, F3-1, F3-9		

USER'S RESPONSE SHEET

Manual Title: Model 990 Computer Model DS10 Cartridge System
Installation and Operation (946261-9701 *B)

Manual Date: 15 December 1980 Date of This Letter: _____

User's Name: _____ Telephone: _____

Company: _____ Office/Department: _____

Street Address: _____

City/State/Zip Code: _____

Please list any discrepancy found in this manual by page, paragraph, figure, or table number in the following space. If there are any other suggestions that you wish to make, feel free to include them. Thank you.

CUT ALONG LINE

Location in Manual	Comment/Suggestion
_____	_____
_____	_____
_____	_____
_____	_____
_____	_____
_____	_____
_____	_____
_____	_____
_____	_____
_____	_____
_____	_____
_____	_____
_____	_____
_____	_____
_____	_____

NO POSTAGE NECESSARY IF MAILED IN U.S.A.
FOLD ON TWO LINES (LOCATED ON REVERSE SIDE), TAPE AND MAIL

FOLD



NO POSTAGE
NECESSARY
IF MAILED
IN THE
UNITED STATES

BUSINESS REPLY MAIL
FIRST CLASS PERMIT NO. 7284 DALLAS, TX

POSTAGE WILL BE PAID BY ADDRESSEE

TEXAS INSTRUMENTS INCORPORATED
DIGITAL SYSTEMS GROUP

ATTN: TECHNICAL PUBLICATIONS
P.O. Box 2909 M/S 2146
Austin, Texas 78769

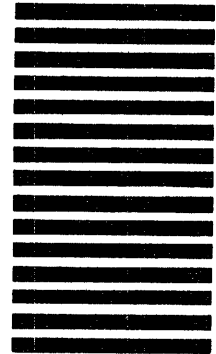

FOLD

Texas Instruments U.S. District Sales and Service Offices

(A complete listing of U.S. offices is available from the district office nearest your location)

California

831 S. Douglas Street
El Segundo, California 90245
(213) 973-2571

100 California Street
Suite 480
San Francisco, California 94111
(415) 781-9470

776 Palomar Avenue
P.O. Box 9064
Sunnyvale, California 94086
(408) 732-1840*

3186 Airway
Suite J
Costa Mesa, California 92626
(714) 540-7311

Colorado

9725 East Hampden Avenue
Suite 301
Denver, Colorado 80231
(303) 751-1780

Florida

1850 Lee Road
Suite 115
Winter Park, Florida 32789
(305) 644-3535

Georgia

3300 Northeast Expressway
Building 9
Atlanta, Georgia 30341
(404) 458-7791

Illinois

515 West Algonquin Road
Arlington Heights, Illinois 60005
(312) 640-2900
(800) 942-0609*

Massachusetts

504 Totten Pond Road
Waltham, Massachusetts 02154
(617) 890-7400

Michigan

24293 Telegraph Road
Southfield, Michigan 48034
(313) 353-0830
(800) 572-8740*

Minnesota

7625 Parklawn Avenue
Minneapolis, Minnesota 55435
(612) 830-1600

Missouri

2368 Schuetz
St. Louis, Missouri 63141
(314) 569-0801*

New Jersey

1245 Westfield Avenue
Clark, New Jersey 07066
(201) 574-9800

Ohio

4124 Linden Avenue
Dayton, Ohio 45432
(513) 258-3877

Pennsylvania

420 Rouser Road
Coraopolis, Pennsylvania 15108
(412) 771-8550

Texas

8001 Stemmons Expressway
P.O. Box 226080
M/S 3108
Dallas, Texas 75266
(214) 689-4460

13510 North Central Expressway
P.O. Box 225214
M/S 393
Dallas, Texas 75265
(214) 238-3881

9000 Southwest Freeway, Suite 400
Houston, Texas 77074
(713) 776-6577

8585 Commerce Drive, Suite 518
Houston, Texas 77036
(713) 776-6531
(713) 776-6553*

Virginia

1745 Jefferson Davis Highway
Crystal Square 4, Suite 600
Arlington, Virginia 22202
(703) 553-2200

Wisconsin

205 Bishops Way
Suite 214
Brookfield, Wisconsin 53005
(414) 784-1323

*Service telephone number

TI-CARE*

**Centralized Dispatch Telephone Numbers
for Requesting Service**

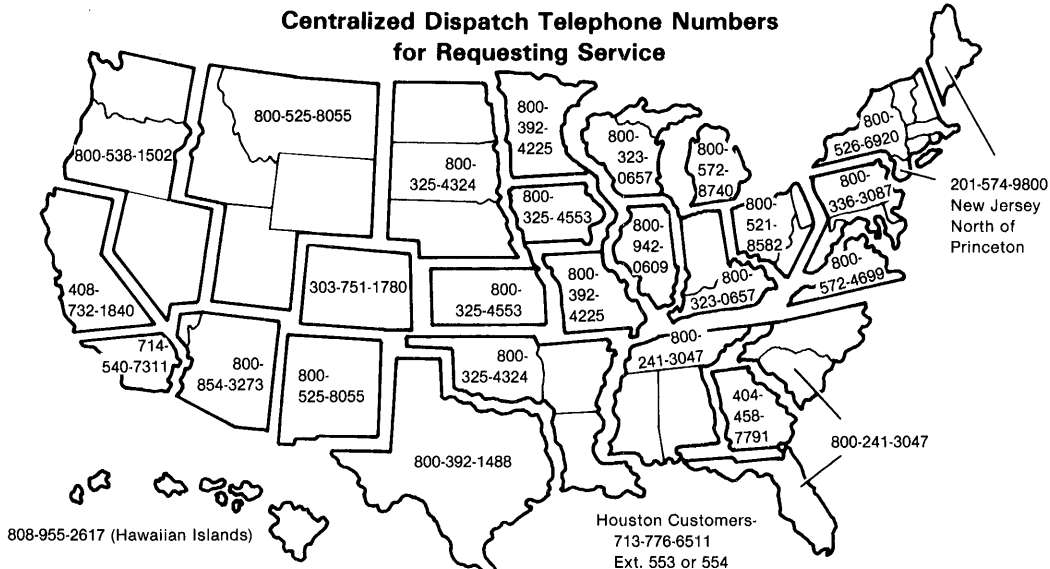

*Service mark of Texas Instruments

The **TI Customer Support Line** is available to answer our customers' complex technical questions. The extensive experience of a selected group of TI senior engineers and systems analysts is made available directly to our customers. The **TI Customer Support Line** telephone number is (512) 250-7407.



TEXAS INSTRUMENTS

INCORPORATED

DIGITAL SYSTEMS GROUP

POST OFFICE BOX 2909

AUSTIN, TEXAS